

NO	DESCRIPTION	MATERIAL	Q'TY	FINISH	REMARK
1	BODY 1	BRASS	1	NICKEL	B-SMA0043-N
2	BODY 2	BRASS	1	NICKEL	B-SMA0154-N
3	RUBBER 1	SI RUBBER	1	RUBBER	RU-0007
4	WASHER	PH.BRONZE	1	NICKEL	W-0012
5	INSULATION 1	TEFLON	1	TEFLON	I-0126T
6	BODY 3	BRASS	1	NICKEL	B-UHF0682-N
7	INSULATION 2	TEFLON	1	TEFLON	I-0328T
8	WASHER	BRASS	1	NICKEL	W-0058-N
9	PIN	BRASS	1	GOLD	P-UHF0460-G

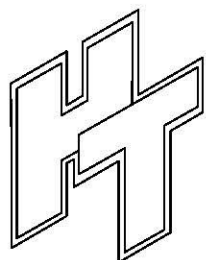
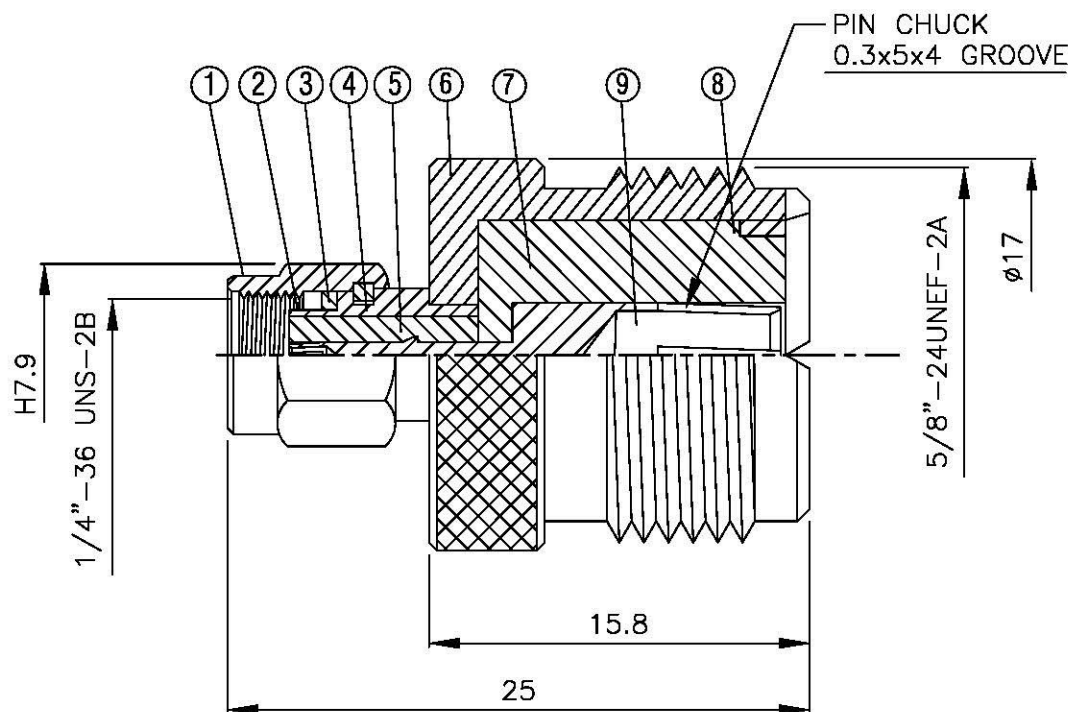
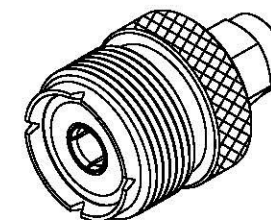

**All Connectors**

www.allconnectors.de  
tel.: 0049 (0) 40 000500  
20794 Fildermoor, Germany

info@allconnectors.de  
fax: 0049 (0) 40 000504  
Kottbusstr. 25

TITLE SMA MALE-UHF FEMALE ADAPTOR  
(REVERSE POLARITY)

PART NO. SMA-29-TGN-RP

DRAWING NO. SMA 29 TGN-RP

DRAWN MARY DATE 90.02.17

CHECKED 蘇姿潔 DATE

Q.A. 馮健華 DATE

APPROVAL 徐燦霖 DATE

REVISION DATE

DIMENSIONS ARE IN MILLIMETERS

UNLESS OTHERWISE SPECIFIED  
TOLERANCE

0.5-5=±0.2 120-315=±1

5-30=±0.4 315-1000=±1.6

30-120±0.6 1000-2000=±2.4

SCALE 4:1 SIZE A

REVISION

DESCRIPTION ENGINEER

D

C

B

A

D

C

B

A

4

3

2

1