

NO	DESCRIPTION	MATERIAL	Q'TY	FINISH	REMARK
1	BODY	BRASS	1	NICKEL	B-SMA0043-N
2	GASKET	SI RUBBER	1	RUBBER	RU-0008
3	INSULATION	TEFLON	1	TEFLON	I-0134T
4	WASHER	PH. BRONZE	1	GOLD	W-0012
5	BODY	BE CU	1	GOLD	B-SMA0094-N
6	PIN	BRASS	1	GOLD	

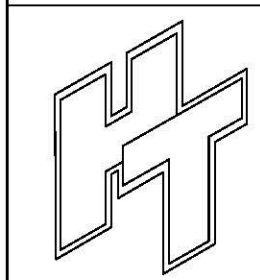
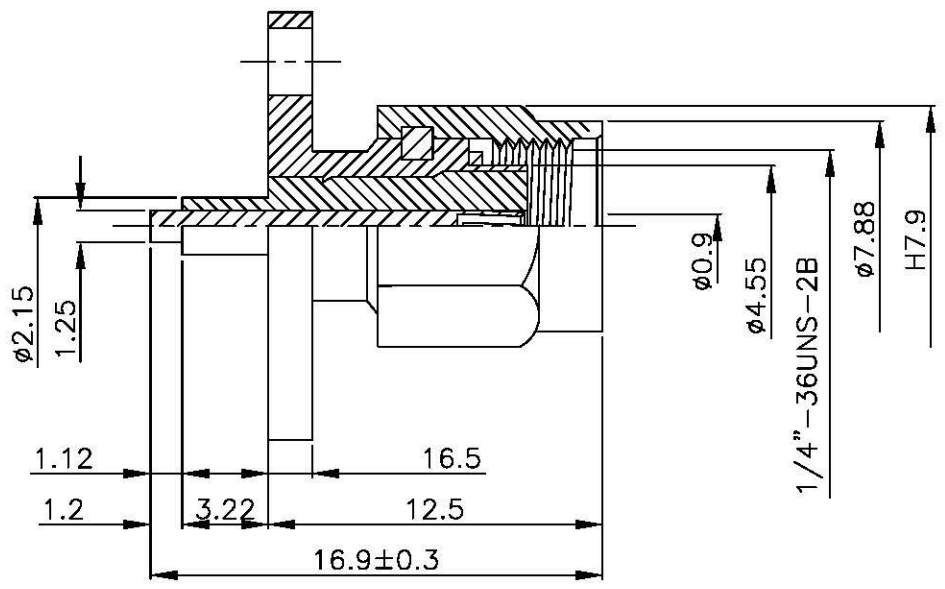
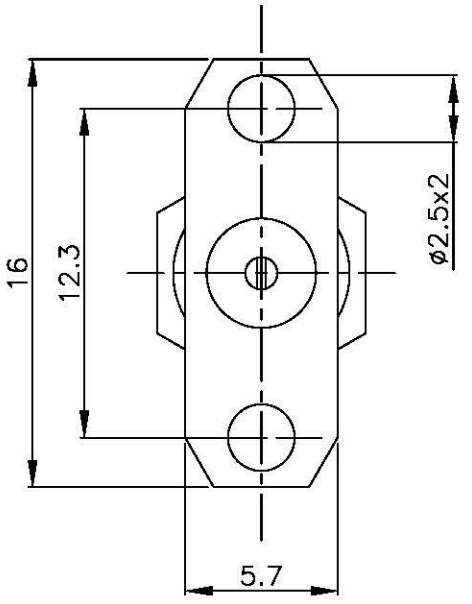
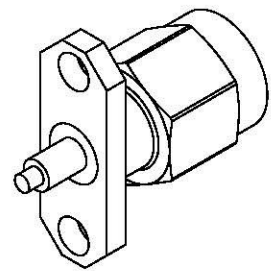

**All Connectors**  
 www.allconnectors.de  
 Tel.: 0049 711 700500  
 All-USA-Hilfsstadt, Germany

info@allconnectors.de  
 Fax: 0049 711 700501  
 Ketzelsiedstr. 25

TITLE SMA FEMALE PANEL RECEPTACLE  
 SOLDER FOR RG 405 REVERSE POLARITY  
 PART NO. SMA-06V7-TGN-RP  
 DRAWING NO. SMA 06V7 TGN RP

DRAWN MARY DATE 96.06.27  
 CHECKED 蘇志欣 DATE  
 Q.A. 蘇姿潔 DATE  
 APPROVAL 徐燦霖 DATE  
 REVISION DATE

DIMENSIONS ARE IN MILLIMETERS  
 UNLESS OTHERWISE SPECIFIED TOLERANCES  
 0.5-5=±0.2 120-315=±1  
 5-30=±0.4 315-1000=±1.6  
 30-120=±0.6 1000-2000=±2.4  
 SCALE 5:1 SIZE A

REVISION	
DESCRIPTION	ENGINEER