

NO	DESCRIPTION	MATERIAL	Q'TY	FINISH	REMARK
1	NUT	BRASS	1	NICKEL	N-0006
2	WASHER	BRASS	1	NICKEL	W-0016
3	GASKET	SI RUBBER	1	RUBBER	RU-0014
4	INSULATION	TEFLON	1	TEFLON	I-0563T
5	BODY	BRASS	1	NICKEL	B-SMA0205-N
6	PIN	BRASS	1	GOLD	P-SAM0804-G
7	INSULATION	TEFLON	1	TEFLON	I-0229T
8	BODY	BRASS	1	NICKEL	B-SMA0473-N

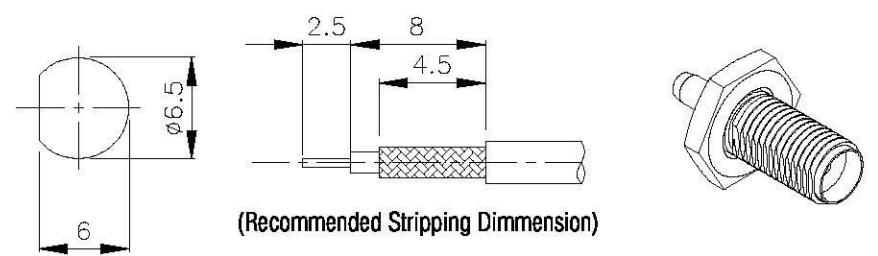

(Recommended Stripping Dimension)

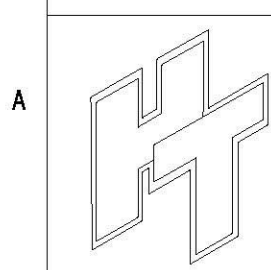
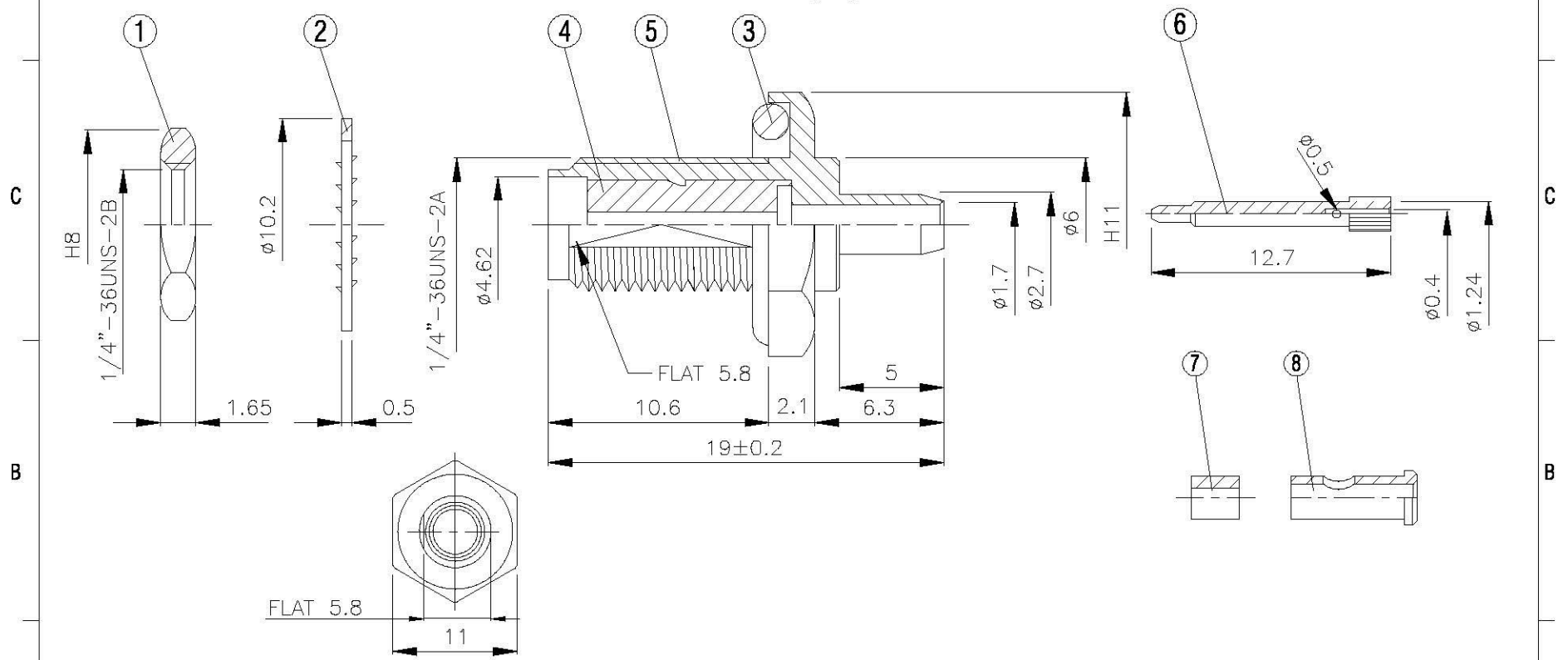

All Connectors
 www.allconnectors.de
 info@allconnectors.de
 TEL: 0049 (0)11 3005343
 70794 Filderstadt, Germany
 FAX: 0049 (0)11 3005344
 80-Herrsching, 25

TITLE SMA FEMALE CRIMP REVERSE POLARITY FOR 178/U

PART NO. SMA-05M-TGN-RP

DRAWING NO. SMA 05M TGN RP

DRAWN	MARY	DATE	06.01.18
CHECKED	蘇姿潔	DATE	
Q.A.	馮健華	DATE	
APPROVAL	徐燦霖	DATE	
REVISION		DATE	

DIMENSIONS ARE IN MILLIMETERS			
UNLESS OTHERWISE SPECIFIED TOLERANCE			
0.5-5=±0.2	120-315=±1		
5-30=±0.4	315-1000=±1.6		
30-120=±0.6	1000-2000=±2.4		
SCALE	4:1	SIZE	A

REVISION	
DESCRIPTION	ENGINEER