

NO	DESCRIPTION	MATERIAL	Q'TY	FINISH	REMARK
1	BODY 1	BRASS	1	NICKEL	B-SMA0209-N
2	INSULATION 1	TEFLON	1	TEFLON	I-0547T
3	PIN	BRASS	1	GOLD	P-SMA0119-G
4	INSULATION 2	TEFLON	1	TEFLON	I-0229T
5	BODY 2	BRASS	1	NICKEL	B-SMA0473-N

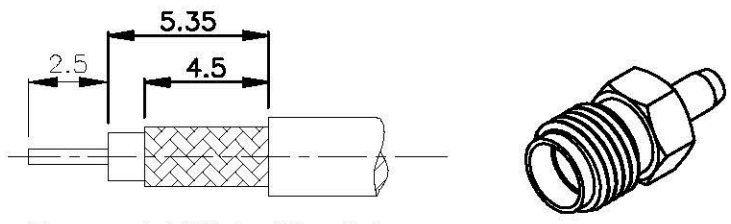

(Recommended Stripping Dimension)

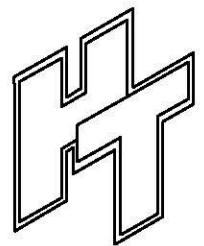
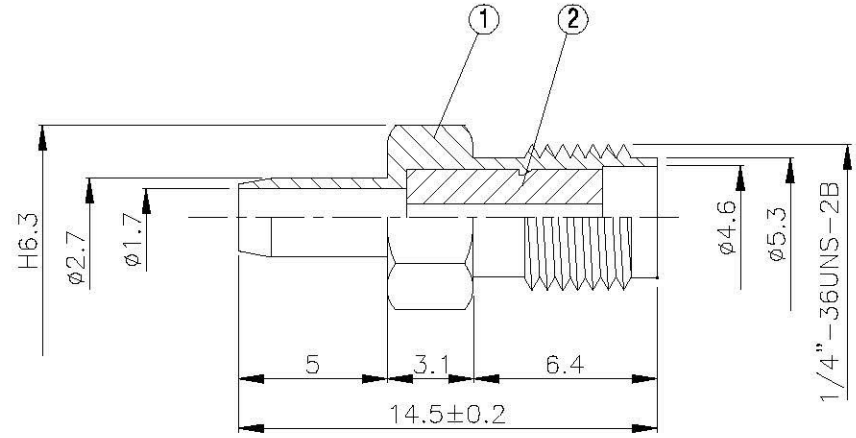
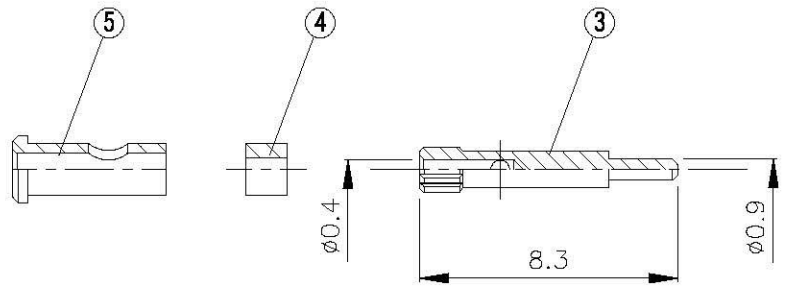

Allconnectors

www.allconnectors.de
 info@allconnectors.de
 41263 Halbesbach - Germany

**TITLE SMA FEMALE CRIMP FOR
 RG-178/U (REVERSE POLARITY)**

PART NO. SMA-04M-TGN-RP

DRAWING NO. SMA 04M TGN-RP

DRAWN MARY **DATE 90.10.23**

CHECKED 蘇姿潔 **DATE**

Q.A. 馮健華 **DATE**

APPROVAL 徐燦霖 **DATE**

REVISION **DATE**

DIMENSIONS ARE IN MILLIMETERS

**UNLESS OTHERWISE SPECIFIED
 TOLERANCES**
 0.5-5=±0.2 120-315=±1
 5-30=±0.4 315-1000=±1.6
 30-120=±0.6 1000-2000=±2.4

SCALE 4:1 **SIZE A**

REVISION

DESCRIPTION **ENGINEER**