

NO	DESCRIPTION	MATERIAL	Q'TY	FINISH	REMARK
1	BODY	BRASS	1	NICKEL	B-SMA0062-N
2	INSULATION	TEFLON	1	TEFLON	I-0547T
3	PIN	BRASS	1	GOLD	P-SMA0040-G
4	RING	BRASS	1	GOLD	R-0002-G

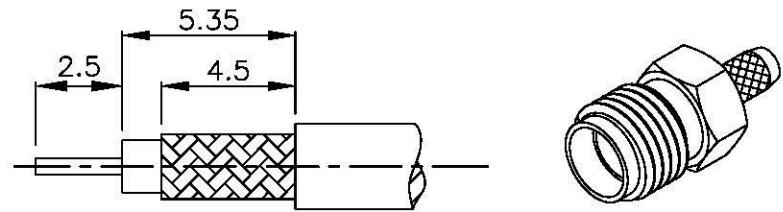

(Recommended Stripping Dimension)

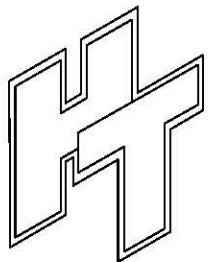
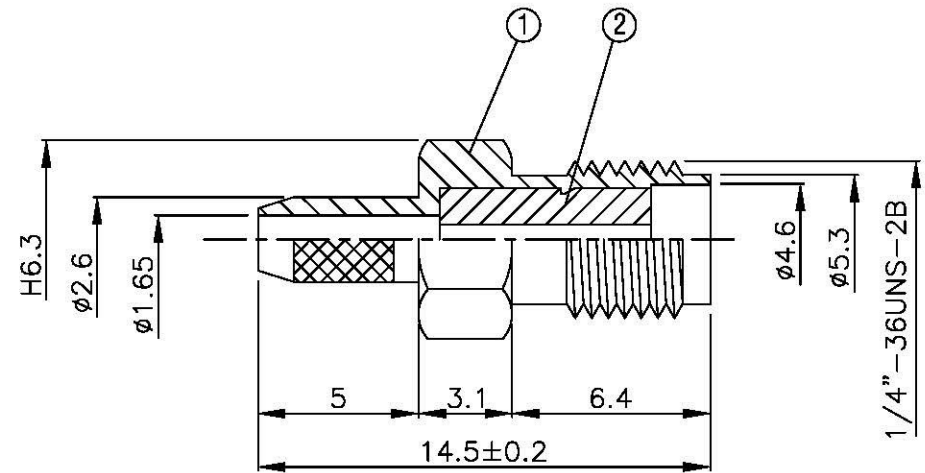
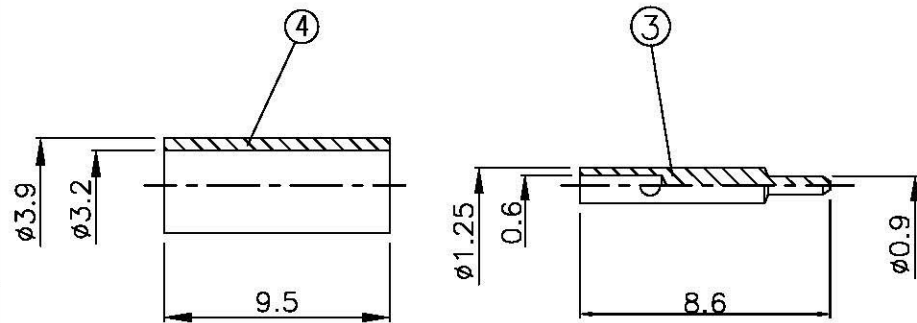

Allconnectors

www.allconnectors.de
Tel: 0049 711 4099209
41234 Hildesheim - Germany

info@allconnectors.de
Fax: 0049 711 4099204
Kontaktcenter: 24h

TITLE SMA FEMALE CRIMP FOR
174/U,316/U REVERSE POLARITY

PART NO. SMA-04LV1-TGN-RP

DRAWING NO. SMA 04LV1 TGN RP

DRAWN MARY DATE 96.01.04

CHECKED 黄巧君 DATE

Q.A. 蘇姿潔 DATE

APPROVAL 徐燦霖 DATE

REVISION DATE

DIMENSIONS ARE IN MILLIMETERS

UNLESS OTHERWISE SPECIFIED
TOLERANCES

0.5-5=±0.2 120-315=±1

5-30=±0.4 315-1000=±1.6

30-120=±0.6 1000-2000=±2.4

SCALE 4:1 SIZE A

REVISION

DESCRIPTION ENGINEER

D

C

B

A

D

C

B

A

4

3

2

1