

NO	DESCRIPTION	MATERIAL	Q'TY	FINISH	REMARK
1	SHELL	BRASS	1	GOLD	B-SMA0043-G
2	GASKET	SI RUBBER	1	RUBBER	RU-0008
3	INSULATION	TEFLON	1	TEFLON	I-0115T
4	WASHER	PH.BRONZE	1	GOLD	W-0012
5	BODY	BRASS	1	GOLD	B-SMA0008-G
6	PIN	BE CU	1	GOLD	P-SMA0761-G

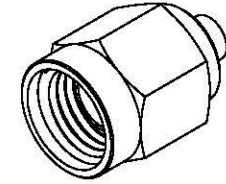

(Recommended Stripping Dimension)

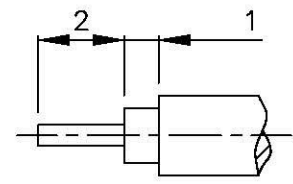
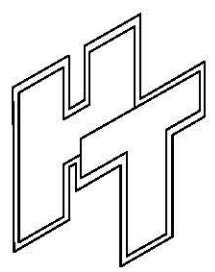
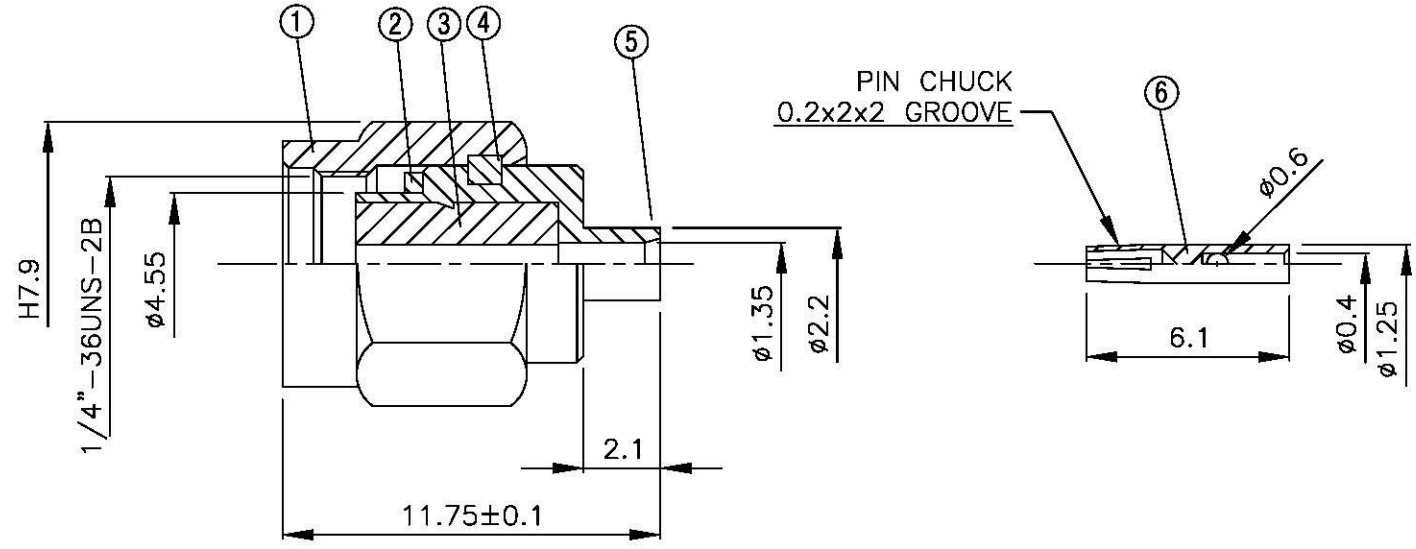

All Connectors
 www.allconnectors.de info@allconnectors.de
 Tel: 0049 711 709909 Fax: 0049 711 709904
 70754 Filderstadt - Germany Kellernstr. 25

TITLE SMA MALE SOLDER FOR .047 REVERSE POLARITY

PART NO. SMA-03V3-TGG-RP

DRAWING NO. SMA 03V3 TGG RP

DRAWN MARY **DATE 96.06.27**

CHECKED 蘇志欣 **DATE**

Q.A. 蘇姿潔 **DATE**

APPROVAL 徐燦霖 **DATE**

REVISION **DATE**

DIMENSIONS ARE IN MILLIMETERS

UNLESS OTHERWISE SPECIFIED TOLERANCE

0.5-5=±0.2 120-315=±1
 5-30=±0.4 315-1000=±1.6
 30-120±0.6 1000-2000=±2.4

SCALE 4:1 **SIZE A**

REVISION	
DESCRIPTION	ENGINEER