

NO	DESCRIPTION	MATERIAL	Q'TY	FINISH	REMARK
1	SHELL	BRASS	1	GOLD	B-SMA0043-G
2	GASKET	SI RUBBER	1	RUBBER	RU-0008
3	INSULATION	TEFLON	1	TEFLON	I-0115T
4	WASHER	PH.BRONZE	1	GOLD	W-0012
5	BODY	BRASS	1	GOLD	B-SMA0042-G
6	PIN	BE CU	1	GOLD	P-SMA0038-G

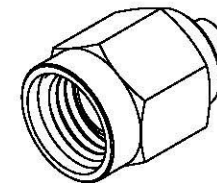

(Recommended Stripping Dimension)

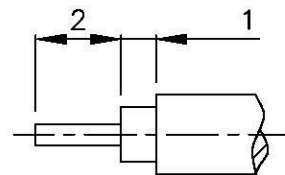
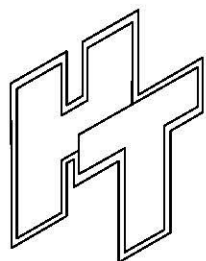
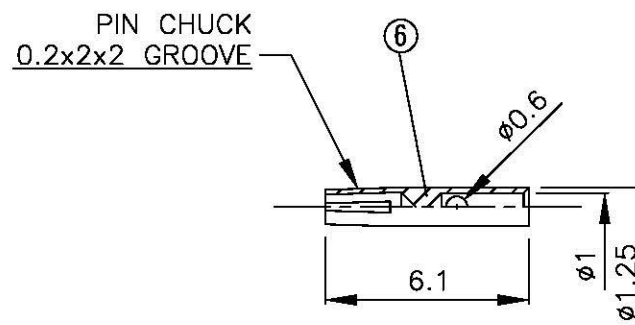
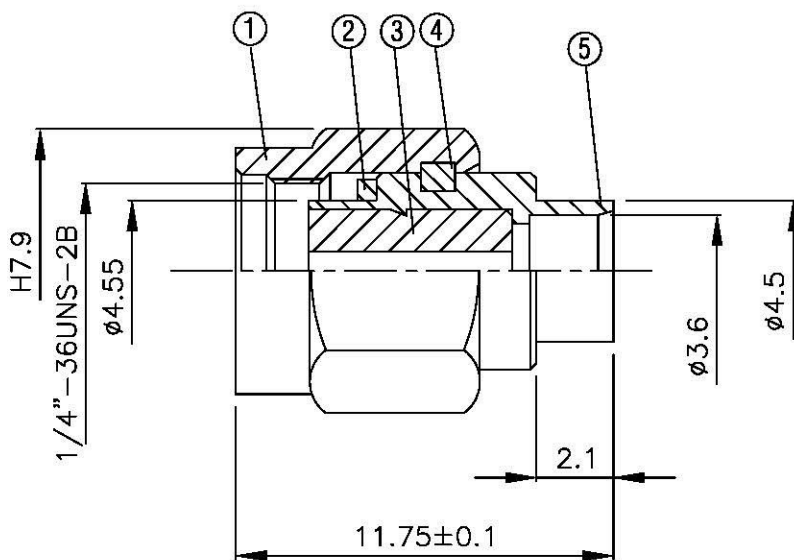

**Allconnectors**

www.allconnectors.de  
Tel: 0049 711 700503  
70794 Waldenstadt Germany

info@allconnectors.de  
Fax: 0049 711 700504  
Kettelerstr. 25

TITLE SMA MALE SOLDER FOR RG402  
REVERSE POLARITY

PART NO. SMA-03V2-TGG-RP

DRAWING NO. SMA 03V2 TGG RP

DRAWN MARY DATE 96.06.27

CHECKED 蘇志欣 DATE

Q.A. 蘇姿潔 DATE

APPROVAL 徐燦霖 DATE

REVISION DATE

DIMENSIONS ARE IN MILLIMETERS

UNLESS OTHERWISE SPECIFIED  
TOLERANCE

0.5-5=±0.2 120-315=±1

5-30=±0.4 315-1000=±1.6

30-120±0.6 1000-2000=±2.4

SCALE 4:1 SIZE A

REVISION

DESCRIPTION ENGINEER