

NO	DESCRIPTION	MATERIAL	Q'TY	FINISH	REMARK
1	SHELL	BRASS	1	GOLD	B-SMA0043-G
2	GASKET	SI RUBBER	1	RUBBER	RU-0008
3	INSULATION	TEFLON	1	TEFLON	I-0115T
4	WASHER	PH.BRONZE	1	GOLD	W-0012
5	BODY	BRASS	1	GOLD	B-SMA0044-G
6	PIN	BE CU	1	GOLD	P-SMA0049-G

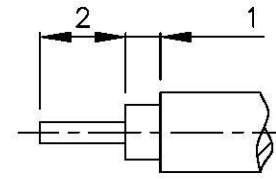

(Recommended Stripping Dimension)

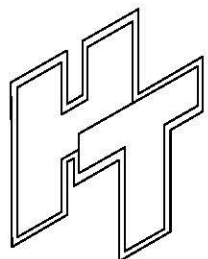
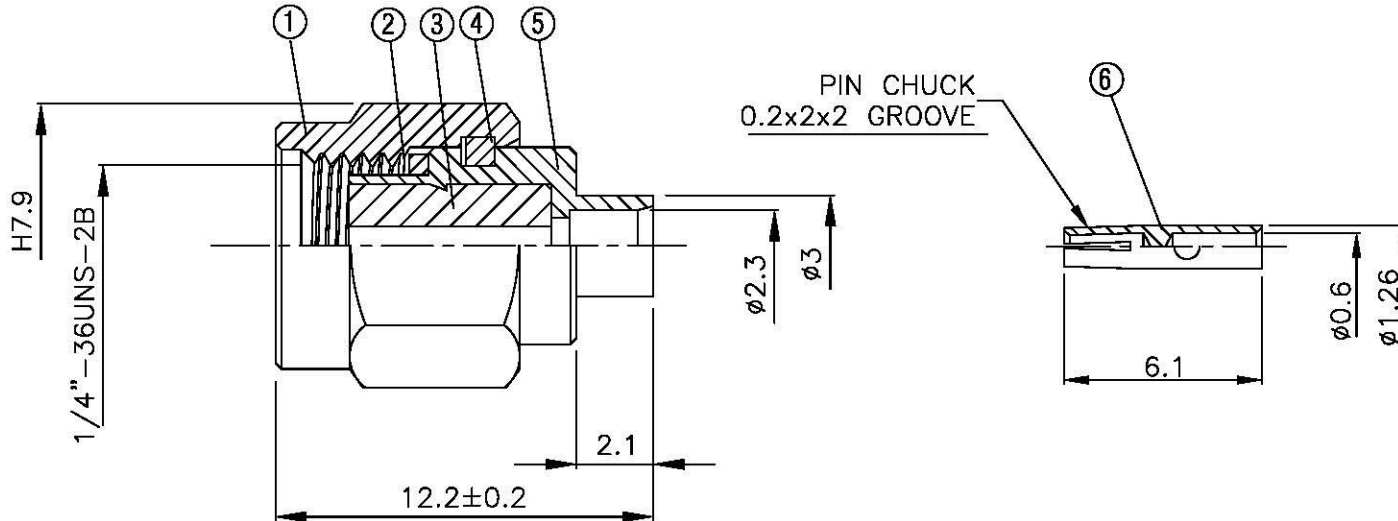
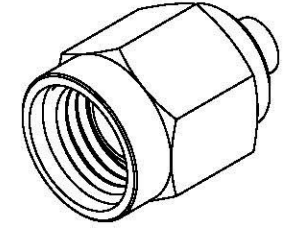

All Connectors

www.allconnectors.de
Tel.: 0049 711 700503
70794 Filberslau - Germany
info@allconnectors.de
Fax: 0049 711 700504
Kellernstr. 25

TITLE SMA MALE SOLDER FOR RG405 (.085) REVERSE POLARITY

PART NO. SMA-03V1-TGG-RP

DRAWING NO. SMA 03V1 TGG-RP

DRAWN MARY DATE 90.02.12

CHECKED 蘇姿潔 DATE

Q.A. 馮健華 DATE

APPROVAL 徐燦霖 DATE

REVISION DATE

DIMENSIONS ARE IN MILLIMETERS

UNLESS OTHERWISE SPECIFIED TOLERANCE

0.5-5 = ± 0.2 120-315 = ± 1
5-30 = ± 0.4 315-1000 = ± 1.6
30-120 = ± 0.6 1000-2000 = ± 2.4

SCALE 4:1 SIZE A

REVISION

DESCRIPTION	ENGINEER