

NO	DESCRIPTION	MATERIAL	Q'TY	FINISH	REMARK
1	SHELL	BRASS	1	NICKEL	B-SMA0043-N
2	GASKET	SI RUBBER	1	RUBBER	RU-0008
3	WASHER	BRASS	1	NICKEL	W-0012
4	INSULATION	TEFLON	1	TEFLON	I-0115T
5	BODY	BRASS	1	NICKEL	B-SMA1036-N
6	PIN	BRASS	GOLD	P-SMA0632-G	
7	RING	BRASS	1	NICKEL	R-0010-N

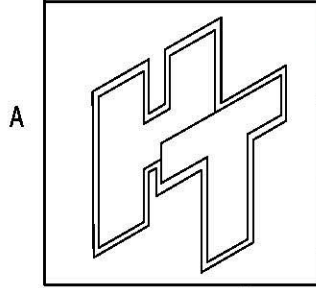
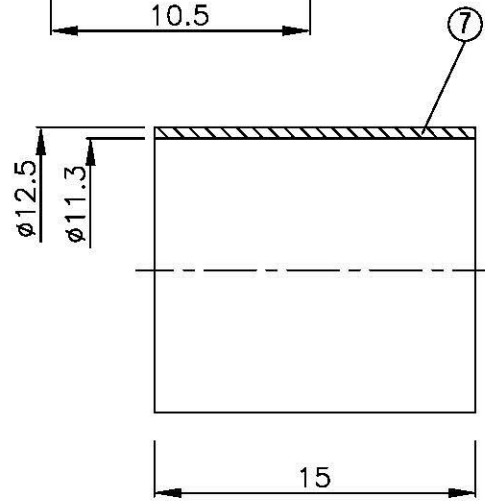
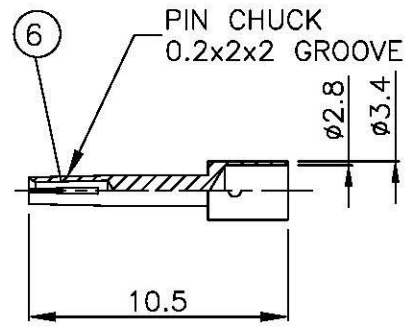
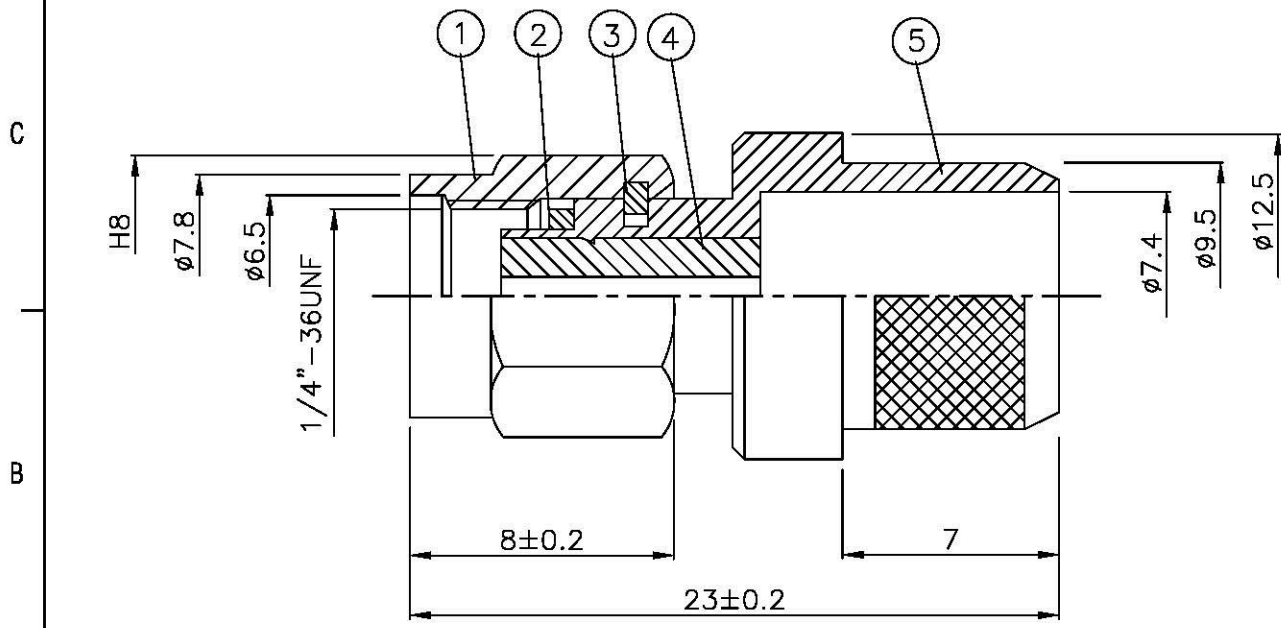
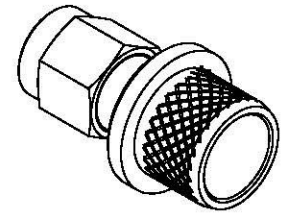
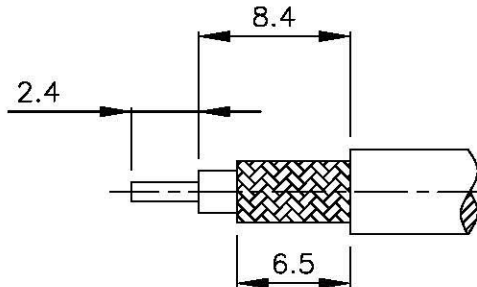

All Connectors
 www.allconnectors.de
 TEL: 0049 711 700503
 76754 Filderstadt - Germany
 info@allconnectors.de
 Fax: 0049 711 700504
 Kettenerstr. 25

TITLE SMA MALE CRIMP
 FOR LMR-400(REVERSE POLARITY)

PART NO. SMA-03S-TGN-RP

DRAWING NO. SMA-03S-TGN-RP

DRAWN MARY
CHECKED 沈佳博
Q.A. 蘇姿潔
APPROVAL 徐燦霖
REVISION

DATE 94.10.05
DATE 94.10.05
DATE
DATE

DIMENSIONS ARE IN MILLIMETERS

UNLESS OTHERWISE SPECIFIED TOLERANCES

0.5-5 = ± 0.2 120-315 = ± 1
 5-30 = ± 0.4 315-1000 = ± 1.6
 30-120 = ± 0.6 1000-2000 = ± 2.4

SCALE 4:1 **SIZE** A

REVISION	
DESCRIPTION	ENGINEER