

NO	DESCRIPTION	MATERIAL	Q'TY	FINISH	REMARK
1	SHELL	BRASS	1	NICKEL	B-SMA0043-N
2	GASKET	SI RUBBER	1	RUBBER	RU-0008
3	WASHER	BRASS	1	NICKEL	W-0012
4	INSULATION	TEFLON	1	TEFLON	I-0115T
5	BODY	BRASS	1	NICKEL	B-SMA0776-N
6	PIN	BRASS	1	GOLD	P-SMA0590-G
7	RING	BRASS	1	NICKEL	R-0064-N

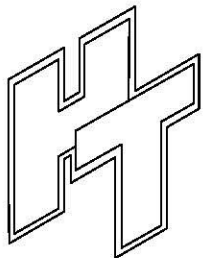
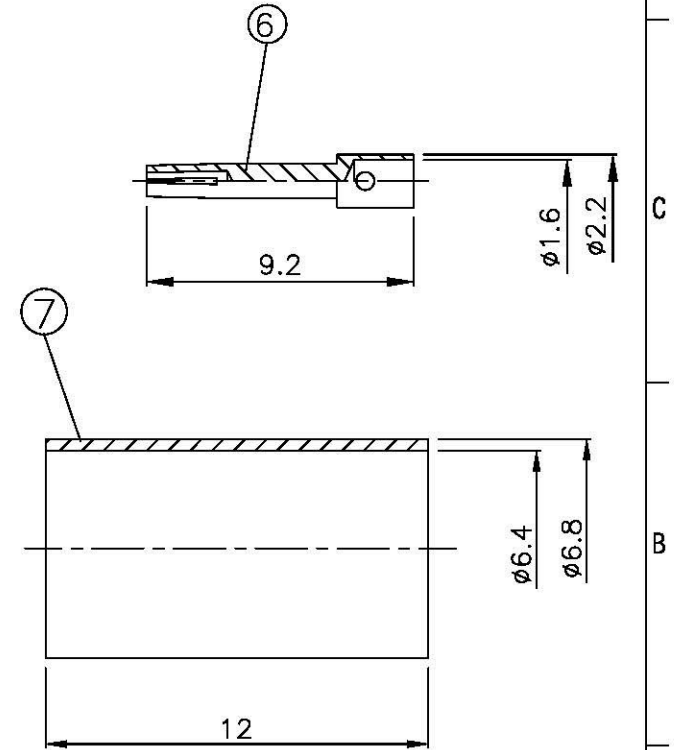
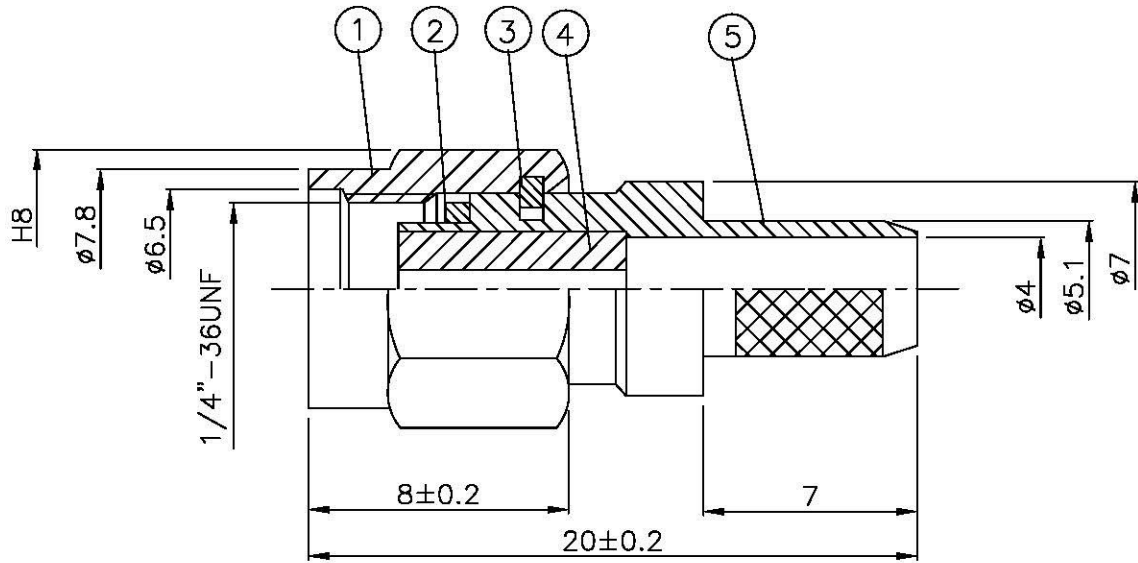
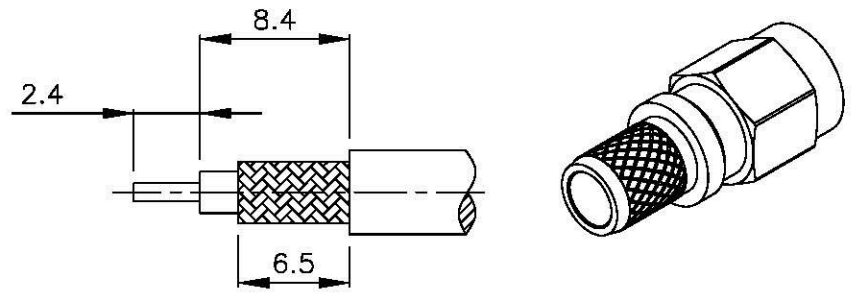

All Connectors
 www.allconnectors.de info@allconnectors.de
 Tel: 03949 073 4000-40 Fax: 03949 073 2000-40
 70754 Ellersdorf, Germany K: 03949 073 2000-40

TITLE
SMA MALE CRIMP REVERSE POLARITY
FOR LMR-240

PART NO.
SMA-03R-TGN-RP

DRAWING NO.
SMA-03R-TGN-RP

DRAWN MARY
CHECKED 蘇姿潔
Q.A. 馮健華
APPROVAL 徐燦霖
REVISION

DATE 93.09.10
DATE 93.09.10
DATE
DATE

DIMENSIONS ARE IN MILLIMETERS
UNLESS OTHERWISE SPECIFIED TOLERANCES
 0.5-5=±0.2 120-315=±1
 5-30=±0.4 315-1000=±1.6
 30-120=±0.6 1000-2000=±2.4
SCALE 4:1 **SIZE** A

REVISION	
DESCRIPTION	ENGINEER