

NO	DESCRIPTION	MATERIAL	Q'TY	FINISH	REMARK
1	SHELL	BRASS	1	NICKEL	B-SMA0043-N
2	GASKET	SI RUBBER	1	RUBBER	RU-0008
3	INSULATION	TEFLON	1	TEFLON	I-0115T
4	WASHER	PH.BRONZE	1	GOLD	W-0012
5	BODY	BRASS	1	NICKEL	B-SMA0045-N
6	PIN	BE CU	1	GOLD	P-SMA0049-G
7	RING	BRASS	1	NICKEL	R-0002-N

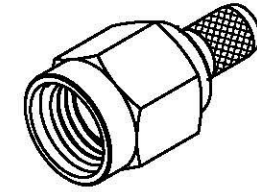

(Recommended Stripping Dimension)

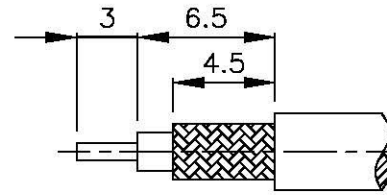
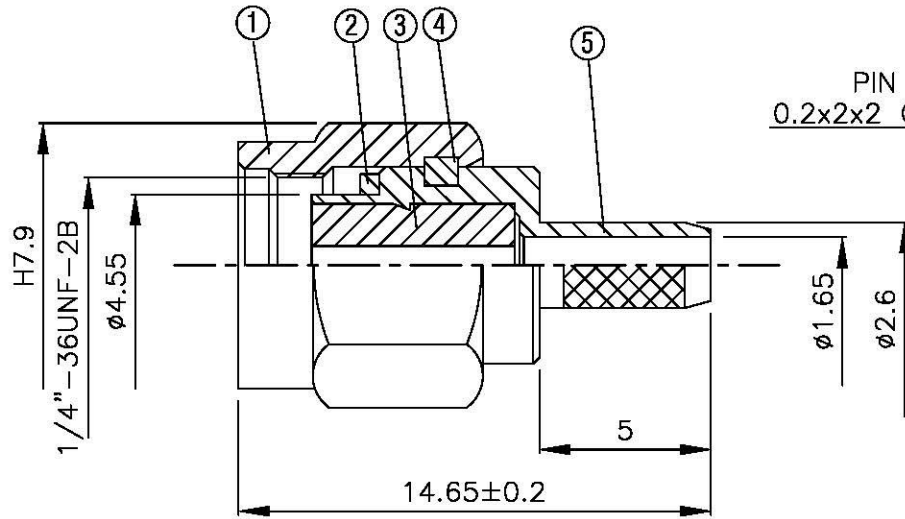

PIN CHUCK
0.2x2x2 GROOVE

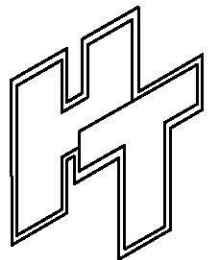
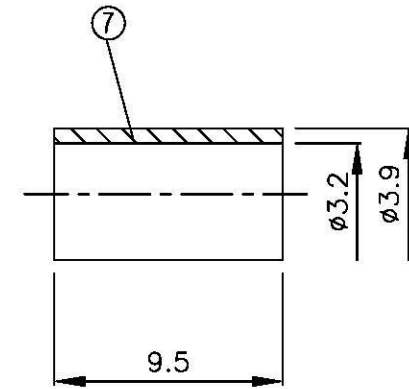
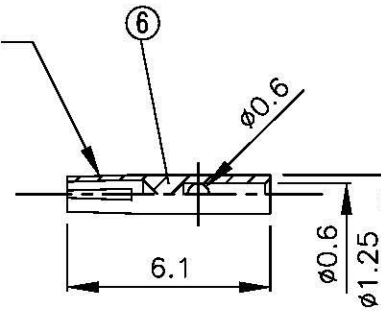

Allconnectors

www.allconnectors.de
Tel.: 0049 711 7004308
70724 Illerstedt - Germany

info@allconnectors.de
Fax: 0049 711 7004301
Kettnerstr. 25

TITLE SMA MALE CRIMP FOR RG174/U
REVERSE PLARITY

PART NO. SMA-03LV1-TGN-RP

DRAWING NO. SMA 03LV1 TGN RP

DRAWN MARY DATE 92.03.01

CHECKED 黃巧君 DATE 96.01.22

Q.A. 蘇姿潔 DATE

APPROVAL 徐燦霖 DATE

REVISION DATE

DIMENSIONS ARE IN MILLIMETERS

UNLESS OTHERWISE SPECIFIED
TOLERANCE
0.5-5=±0.2 120-315=±1
5-30=±0.4 315-1000=±1.6
30-120±0.6 1000-2000=±2.4

SCALE 4:1 SIZE A

REVISION

DESCRIPTION ENGINEER