

NO	DESCRIPTION	MATERIAL	Q'TY	FINISH	REMARK
1	SHELL	BRASS	1	NICKEL	B-SMA0043-N
2	GASKET	SI RUBBER	1	RUBBER	RU-0008
3	INSULATION	TEFLON	1	TEFLON	I-0115T
4	WASHER	PH.BRONZE	1	NICKEL	W-0012
5	BODY	BRASS	1	NICKEL	B-SMA0046-N
6	PIN	BE CU	1	GOLD	P-SMA0038-G
7	RING	BRASS	NICKEL	R-0047-N	

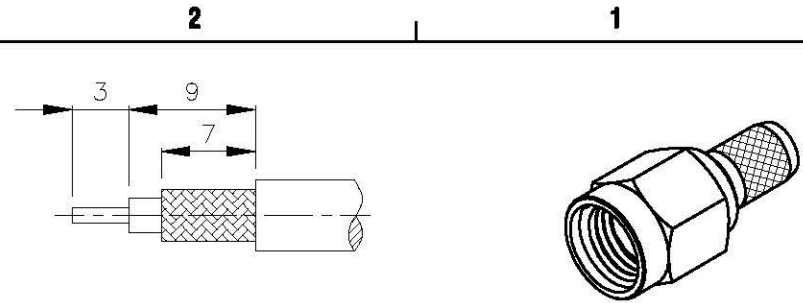

(Recommended Stripping Dimension)

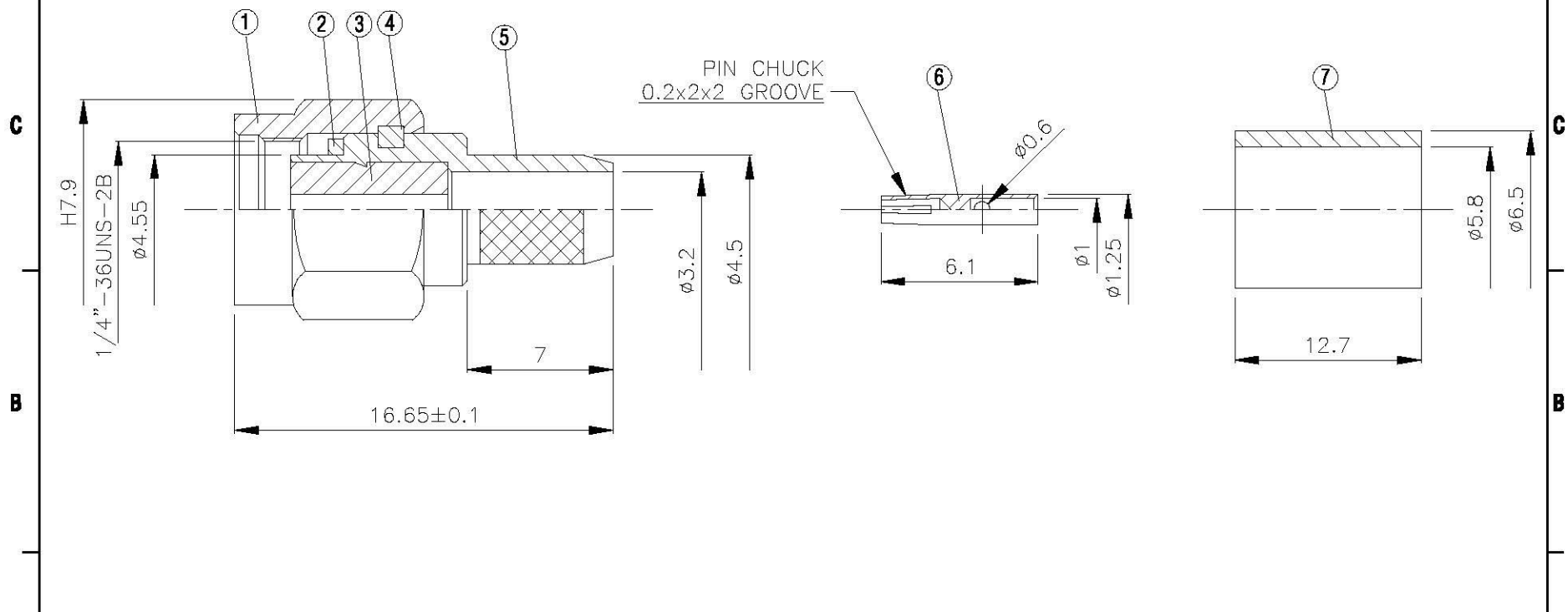

	Allconnectors <small>www.allconnectors.de Tel: 0049 241 7005503 21744 Hildesheim, Germany</small>	DRAWN MARY CHECKED 黄巧君 Q.A. 蘇姿潔 APPROVAL 徐燦霖 REVISION	DATE 90.01.25 DATE 96.01.08 DATE DATE DATE	DIMENSIONS ARE IN MILLIMETERS UNLESS OTHERWISE SPECIFIED TOLERANCE 0.5-5=±0.2 120-315=±1 5-30= ±0.4 315-1000=±1.6 30-120±0.6 1000-2000=±2.4 SCALE 4:1 SIZE A	REVISION DESCRIPTION ENGINEER
	TITLE SMA MALE CRIMP FOR RG-400 RG-142/U REVERSE POLARITY	PART NO. SMA-03FA-TGN-RP	DRAWING NO. SMA 03FA TGN RP		