

NO	DESCRIPTION	MATERIAL	QTY	FINISH	REMARK
1	SHELL	BRASS	1	GOLD	B-SMA0043-G
2	GASKET	SI RUBBER	1	GOLD	RU-0008
3	WASHER	PH.BRONZE	1	GOLD	W-0012-G
4	INSULATION	TEFLON	1	TEFLON	I-0138T
5	PIN	BE CU	1	GOLD	P-SMA0150-G
6	BODY	BRASS	1	GOLD	B-SMB0254-G
7	INSULATION	TEFLON	1	TEFLON	I-0136T
8	WASHER	BRASS	1	GOLD	W-0023-G
9	BODY	BRASS	1	GOLD	B-SMA0154-G

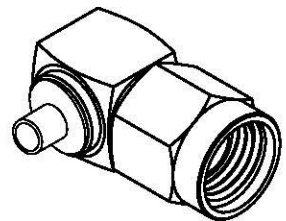

(Recommended Stripping Dimension)

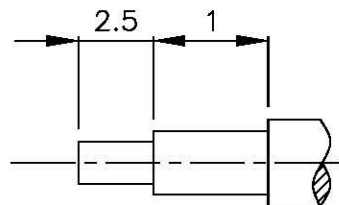
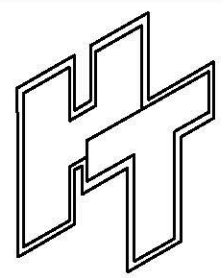
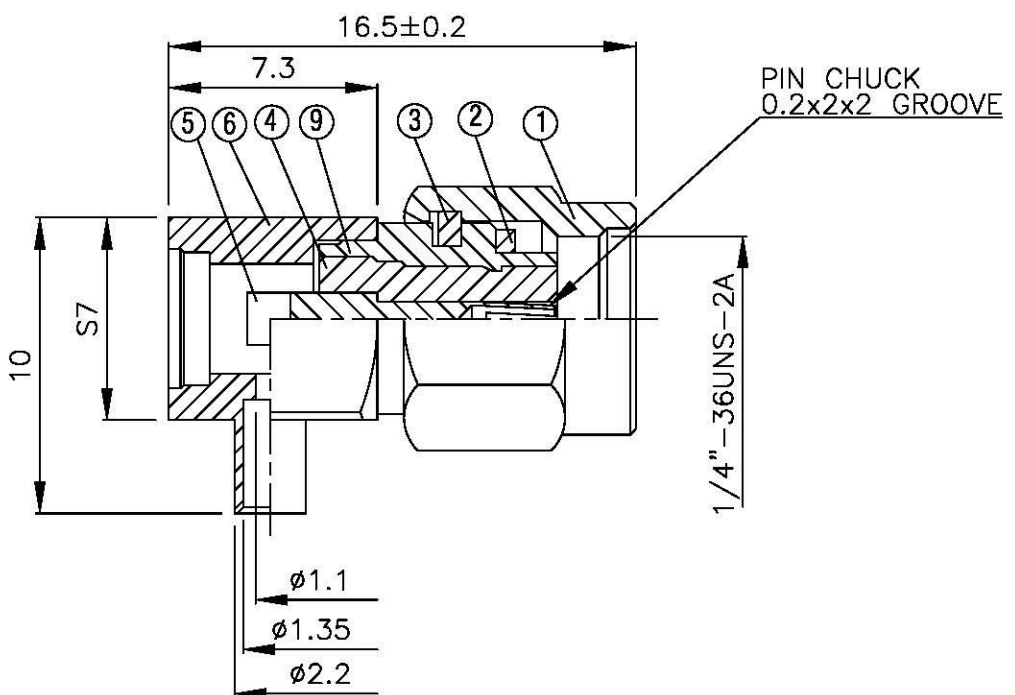
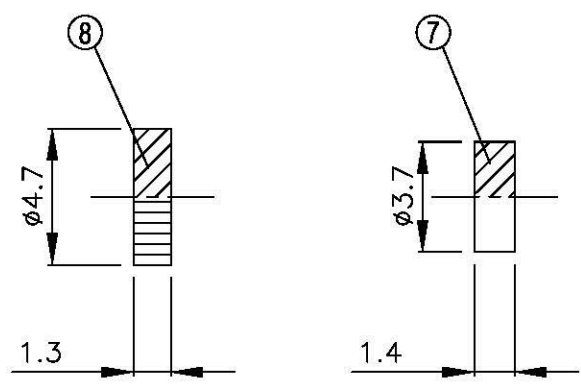

All Connectors
 www.allconnectors.de
 Tel.: 0049 711 7009503
 70794 Filzschlößl - Germany
 info@allconnectors.de
 Fax: 0049 711 7009504
 Kullenwst. 25

TITLE SMA MALE SLDER FOR M17/151(.047)
 REVERSE POLARITY

PART NO. SMA-02V3-TGG-RP

DRAWING NO. SMA 02V3 TGG RP

DRAWN	MARY	DATE	96.03.31
CHECKED	黄巧君	DATE	
Q.A.	蘇姿潔	DATE	
APPROVAL	徐燦霖	DATE	
REVISION		DATE	

DIMENSIONS ARE IN MILLIMETERS			
UNLESS OTHERWISE SPECIFIED TOLERANCE			
0.5-5=±0.2	120-315=±1		
5-30=±0.4	315-1000=±1.6		
30-120±0.6	1000-2000=±2.4		
SCALE	4:1	SIZE	A

REVISION	
DESCRIPTION	ENGINEER