

NO	DESCRIPTION	MATERIAL	Q'TY	FINISH	REMARK
1	BODY 1	SUS303	1	PASSIVATED	B-NSMP1483-SUS
2	INSULATION	TEFLON	1	TEFLON	I-0680T
3	PIN	BE CU	1	GOLD	P-NSMP1015-G

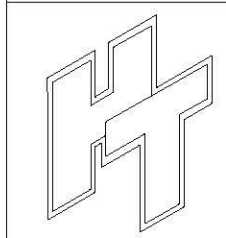
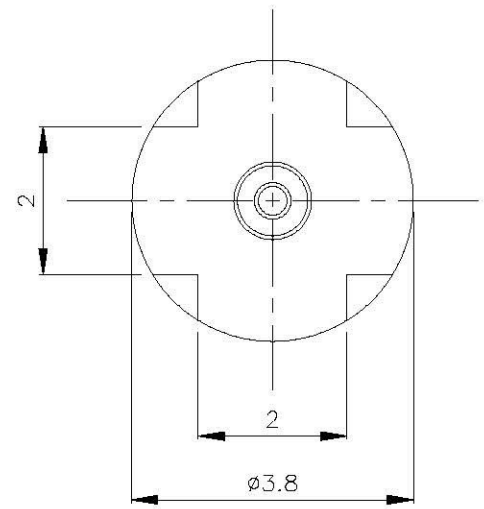
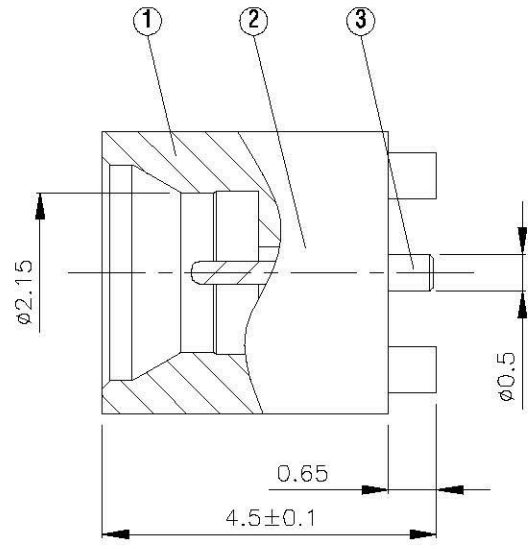
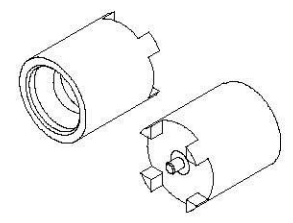
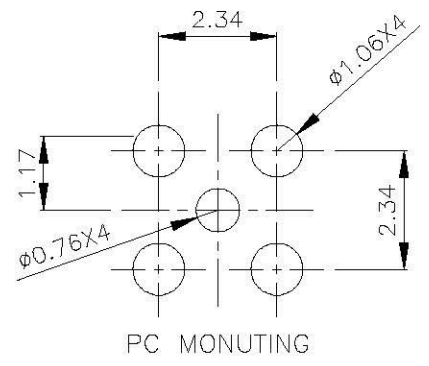

**Allconnectors**  
 www.allconnectors.com  
 Tel: 0049 711 7009269  
 70754 Filzschweil, Germany

info@allconnectors.com  
 Fax: 0049 711 7009264  
 Kottelmerstr. 25

**TITLE** MINI SMP MALE (FULL DETENT)  
PCB SURFACE MOUNT

**PART NO.** NSMP-08-TGSUS

**DRAWING NO.** NSMP-08-TGSUS

**DRAWN** 蘇志欣 **DATE** 98.09.30

**CHECKED** 蘇姿潔 **DATE**

**Q.A.** 莊千慧 **DATE**

**APPROVAL** 徐燦霖 **DATE**

**REVISION** **DATE**

**DIMENSIONS ARE IN MILLIMETERS**

**UNLESS OTHERWISE SPECIFIED TOLERANCE**

0.5-5=±0.2	120-315=±1
5-30=±0.4	315-1000=±1.6
30-120=±0.6	1000-2000=±2.4

**SCALE** 4:1 **SIZE** A

REVISION	
DESCRIPTION	ENGINEER