

NO	DESCRIPTION	MATERIAL	Q'TY	FINISH	REMARK
1	BODY 1	SUS303	1	PASSIVATED	B-NSMP1479-SUS
2	INSULATION	TEFLON	1	TEFLON	I-0680T
3	PIN	PH.BRONZE	1	GOLD	P-NSMP1013-G

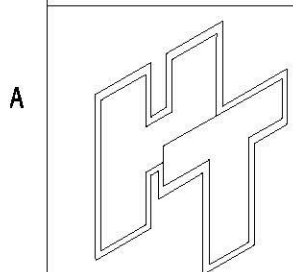
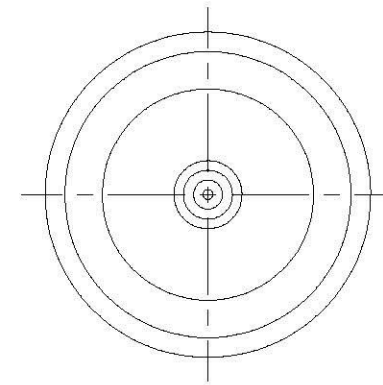
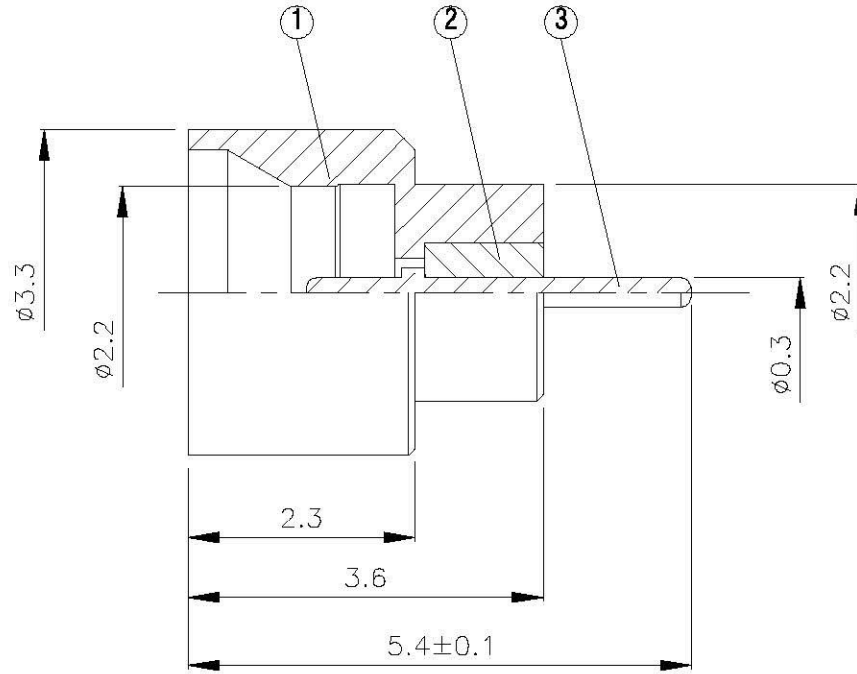
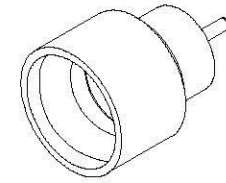

**All Connectors**

www.allconnectors.de info@allconnectors.de  
 TEL: 0049 711 2095001 FAX: 0049 711 2095004  
 70774 Nürting-Geislingen, Germany Kettnerstr. 25

TITLE MINI SMP MALE (FULL DETENT)  
 HERMETIC SOLDER IN SHROUD

PART NO. NSMP-07-TGSUS

DRAWING NO. NSMP-07-TGSUS

DRAWN 蘇志欣

DATE 98.09.24

CHECKED 蘇姿潔

DATE

Q.A. 莊千慧

DATE

APPROVAL 徐燦霖

DATE

REVISION

DATE

DIMENSIONS ARE IN MILLIMETERS

UNLESS OTHERWISE SPECIFIED  
 TOLERANCE

0.5-5 =  $\pm 0.2$  120-315 =  $\pm 1$

5-30 =  $\pm 0.4$  315-1000 =  $\pm 1.6$

30-120 =  $\pm 0.6$  1000-2000 =  $\pm 2.4$

SCALE 4:1 SIZE A

REVISION

DESCRIPTION	ENGINEER

A

A

4

3

2

1