

NO	DESCRIPTION	MATERIAL	Q'TY	FINISH	REMARK
1	BODY	BRASS	1	NICKEL	B-N1340-N
2	WASHER	BRASS	1	NICKEL	W-0036-N
3	INSULATION	TEFLON	1	TEFLON	I-0631T
4	PIN	BRASS	1	GOLD	P-N0925-G

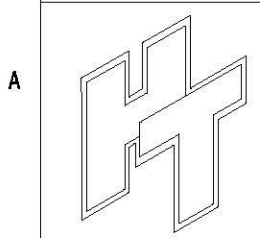
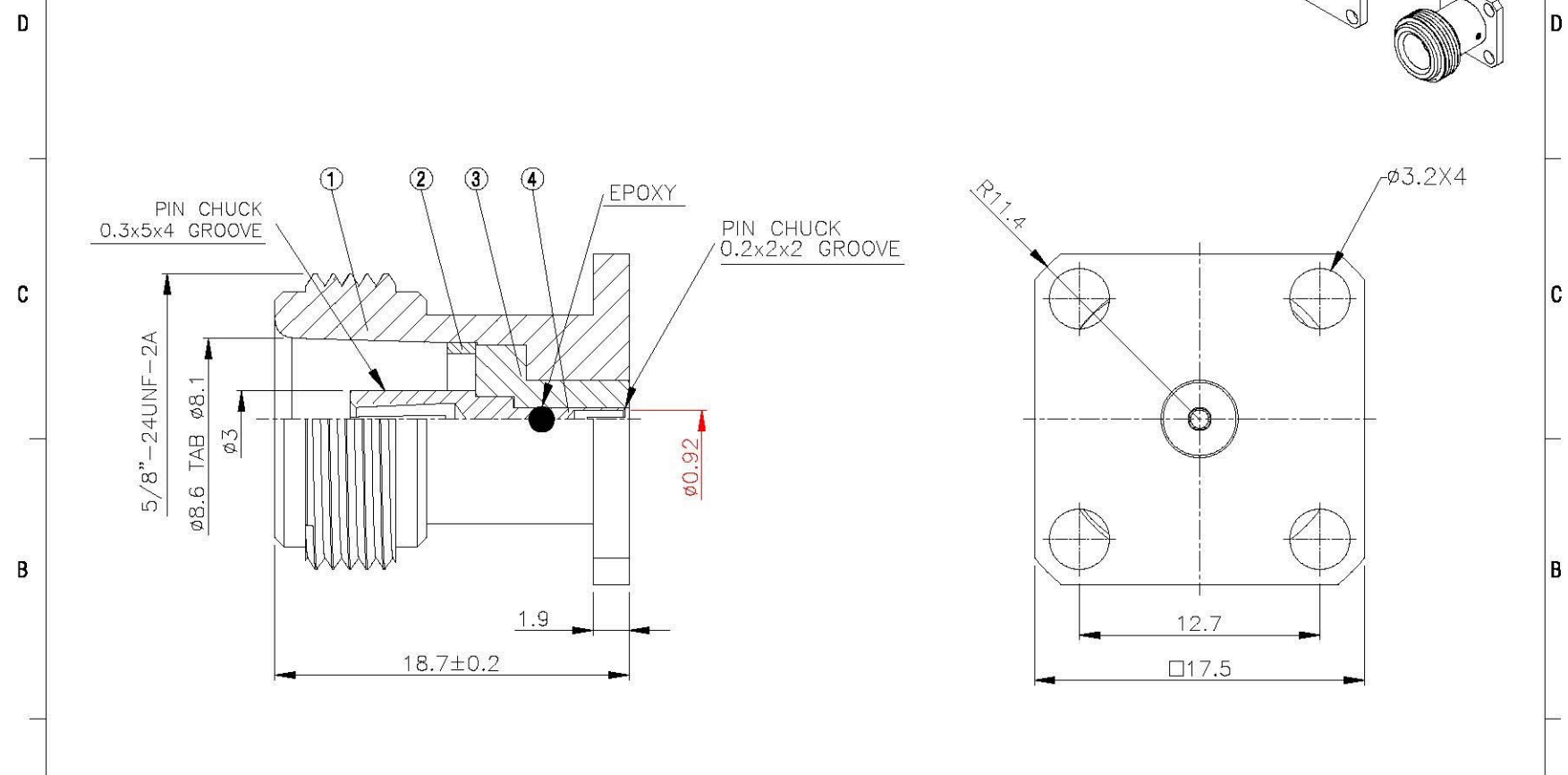
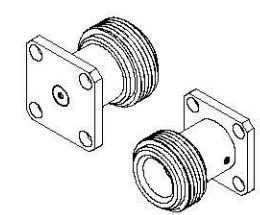

**All Connectors**  
www.allconnectors.de  
 Tel: 0649 211 309600  
 20254 Elmstedt - Germany

**TITLE** N JACK FLANGE MOUNT  
 (ACCEPTS PIN  $\phi 0.92$ )

**PART NO.** N-22V10-TGN

**DRAWING NO.** N-22V10-TGN

**DRAWN** 蘇志欣 **DATE** 97.10.24

**CHECKED** 蘇姿潔 **DATE**

**Q.A.** 林妙樺 **DATE**

**APPROVAL** 徐燦霖 **DATE**

**REVISION** **DATE**

**DIMENSIONS ARE IN MILLIMETERS**

**UNLESS OTHERWISE SPECIFIED TOLERANCE**

0.5-5=±0.2	120-315=±1
5-30=±0.4	315-1000=±1.6
30-120=±0.6	1000-2000=±2.4

**SCALE** 4:1    **SIZE** A

REVISION	
DESCRIPTION	ENGINEER