

NO	DESCRIPTION	MATERIAL	Q'TY	FINISH	REMARK
1	BODY 1	BRASS	1	NICKEL	B-MSM1068-N
2	PIN	PH.BRONZE	1	GOLD	P-MMS0544-G
3	INSULATION 1	TEFLON	1	TEFLON	I-0373T
4	INSULATION 2	TEFLON	1	TEFLON	I-0374T
5	WASHER	BRASS	1	NICKEL	I-0256T
6	BODY 2	BRASS	1	NICKEL	B-FME0861-N

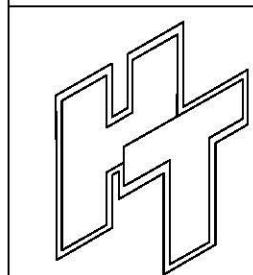
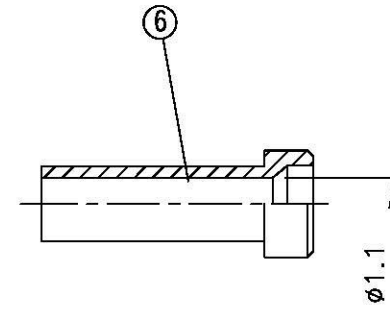
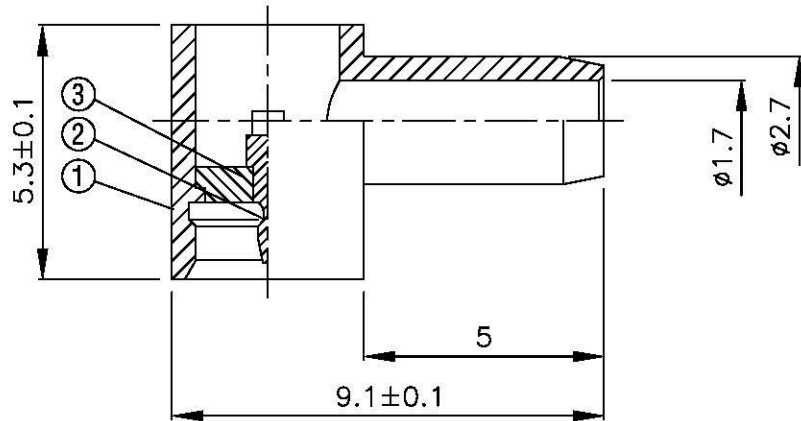
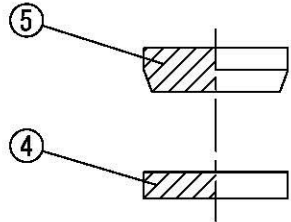
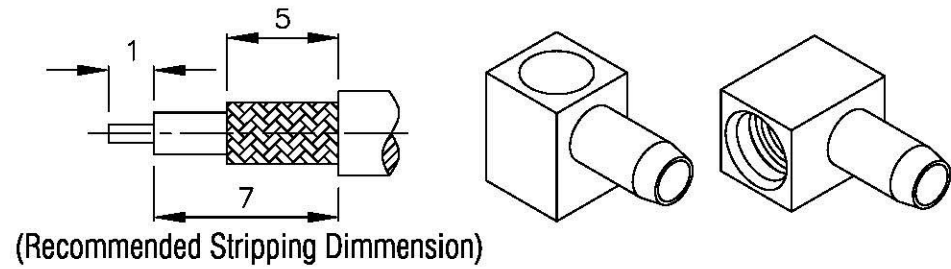

**Allconnectors**  
 www.allconnectors.de info@allconnectors.de  
 Tel: +49 41 21 2185-0 Fax: +49 41 21 2094-14  
 20744 Finkenwall, Germany R: 11.01.2011, 25

TITLE MSM MALE RIGHT ANGLE  
 TYPE FOR HRS 1.3

PART NO. MSM-01U-TGN

DRAWING NO. MSM 01U TGN

DRAWN MARY DATE 96.07.09

CHECKED 蘇志欣

Q.A. 蘇姿潔

APPROVAL 徐燦霖

REVISION

DATE

DATE

DATE

DATE

DIMENSIONS ARE IN MILLIMETERS

UNLESS OTHERWISE SPECIFIED  
 TOLERANCE

0.5-5=±0.2 120-315=±1

5-30=±0.4 315-1000=±1.6

30-120±0.6 1000-2000=±2.4

REVISION

DESCRIPTION ENGINEER

SCALE 4:1 SIZE A