

| NO | DESCRIPTION | MATERIAL | Q'TY | FINISH | REMARK |
|----|-------------|----------|------|----------|-------------|
| 1 | BODY 1 | BRASS | 1 | GOLD | B-MCX0039-G |
| 2 | INSULATION | TEFLON | 1 | TEFLON | I-0490T |
| 3 | BODY 2 | BRASS | 1 | GOLD | B-MCX0040-G |
| 4 | PIN | BE CU | 1 | GOLD | P-MCX0700-G |
| 5 | RING | BRASS | GOLD | R-0001-G | |

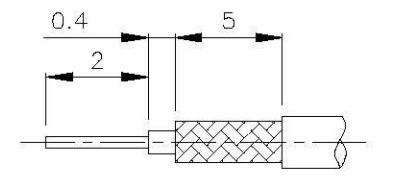

(Recommended Stripping Dimension)

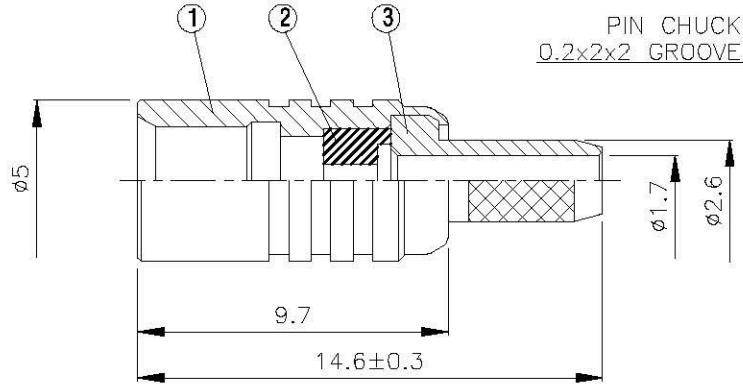
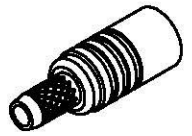

D
C
B
A

D
C
B
A

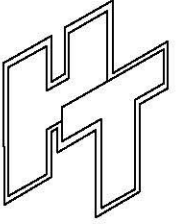

Allconnectors
 www.allconnectors.de
 info@allconnectors.de
 44101 Frankfurt am Main, Germany

Info@allconnectors.de
 Tel: +49 69 401 40140
 Fax: +49 69 401 40141

TITLE MCX FEMALE CRIMP FOR RG179/U
PART NO. MCX-02N-TGG
DRAWING NO. MCX-02N-TGG

| | |
|---------------------|----------------------|
| DRAWN MARY | DATE 94.09.30 |
| CHECKED 蘇志欣 | DATE 96.01.16 |
| Q.A. 蘇姿潔 | DATE |
| APPROVAL 徐燦霖 | DATE |
| REVISION | DATE |

| | | | |
|---|----------------|--|--|
| DIMENSIONS ARE IN MILLIMETERS | | | |
| UNLESS OTHERWISE SPECIFIED TOLERANCE | | | |
| 0.5-5=±0.2 | 120-315=±1 | | |
| 5-30=±0.4 | 315-1000=±1.6 | | |
| 30-120±0.6 | 1000-2000=±2.4 | | |
| SCALE 4:1 | SIZE A | | |

| REVISION | |
|-------------|----------|
| DESCRIPTION | ENGINEER |
| | |
| | |
| | |

4 3 2 1