

NO	DESCRIPTION	MATERIAL	Q'TY	FINISH	REMARK
1	BODY 1	BE CU	1	GOLD	B-MCX0028-G
2	INSULATION	TEFLON	1	TEFLON	I-0490T
3	BODY 2	BRASS	1	GOLD	B-MCX0010-G
4	PIN	BRASS	1	GOLD	P-MCX0702-G
5	RING	BRASS	GOLD	R-0001-G	

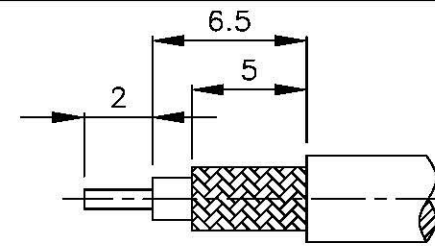

(Recommended Stripping Dimension)

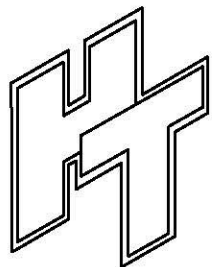
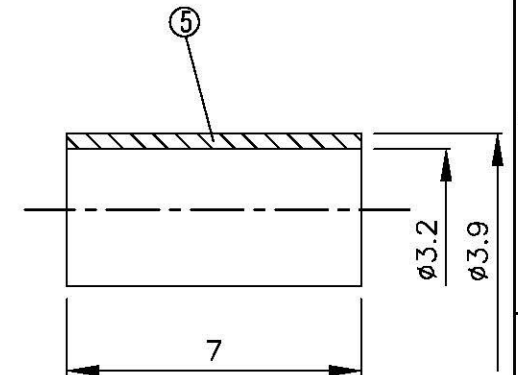
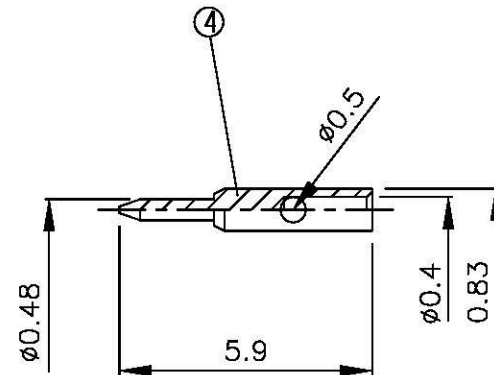
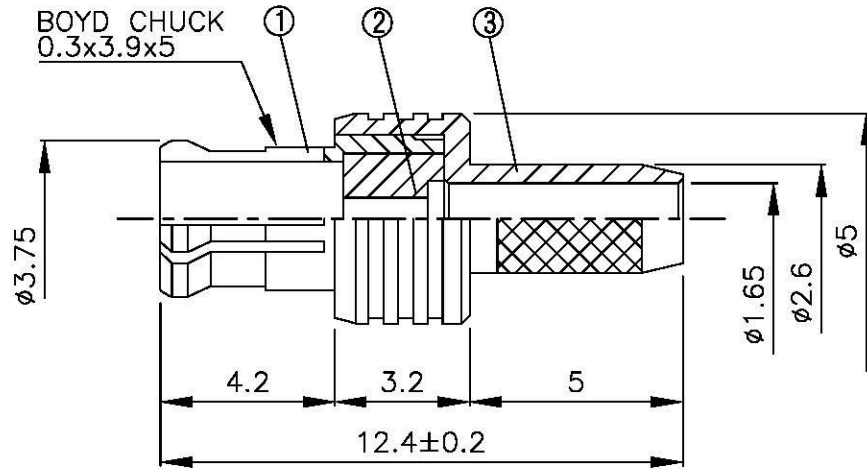

All Connectors

www.allconnectors.de
 info@allconnectors.de
 Tel: 0049 711 4050403 Fax: 0049 711 4050404
 41774 Silbertact - Germany Kettelerstr. 27

TITLE MCX MALE CRIMP FOR RG179U

PART NO. MCX-01N-TGG

DRAWING NO. MCX 01N TGG

DRAWN MARY

DATE 96.04.19

CHECKED 沈佳憶

DATE 96.04.19

Q.A. 蘇姿潔

DATE

APPROVAL 徐燦霖

DATE

REVISION

DATE

DIMENSIONS ARE IN MILLIMETERS

UNLESS OTHERWISE SPECIFIED TOLERANCE

0.5-5=±0.2	120-315=±1
5-30=±0.4	315-1000=±1.6
30-120±0.6	1000-2000=±2.4

SCALE 4:1 SIZE A

REVISION

DESCRIPTION	ENGINEER