

NO	DESCRIPTION	MATERIAL	Q'TY	FINISH	REMARK
1	BODY	BRASS	1	GOLD	B-MCX1184-G
2	RING	BRASS	1	GOLD	R-0001-G

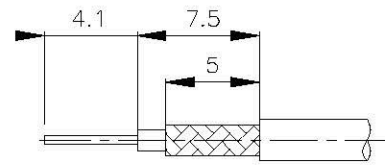

(Recommended Stripping Dimension)

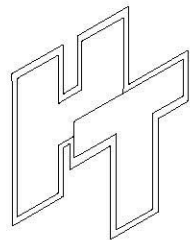
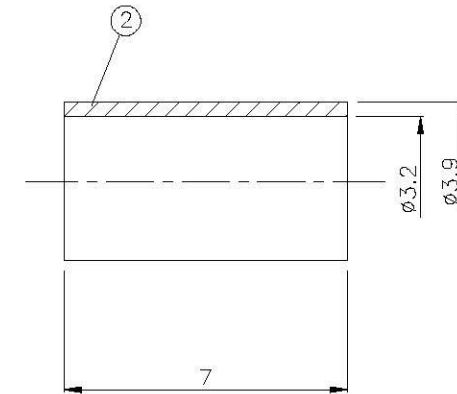
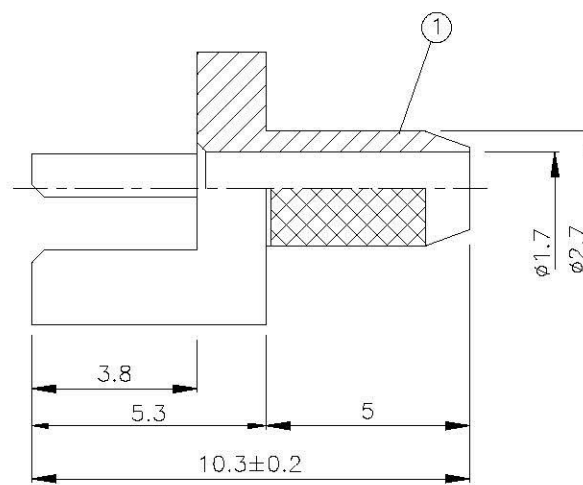
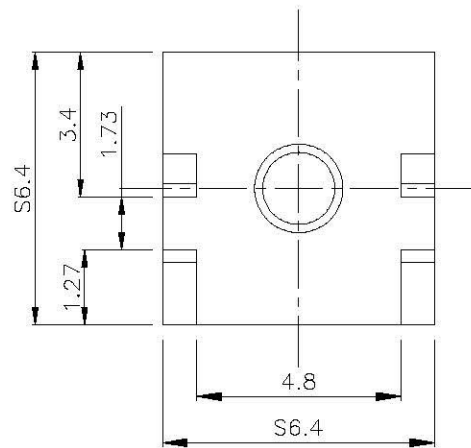
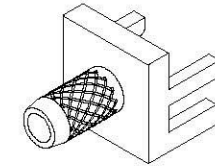

**Allconnectors**

www.allconnectors.de  
Tel.: 0049 711 7005205  
Fax: 0049 711 7005204  
info@allconnectors.de  
Koblenzstr. 42

TITLE STRAIGHT CRIMP END LAUNCH  
TAB CONTACT (BOARD THICKNESS 1.57)

PART NO. MCX-07LV1-GOLD-4

DRAWING NO. MCX-07LV1-GOLD-4

DRAWN MARY DATE 96.05.10

CHECKED 蘇志欣

Q.A. 蘇姿潔

APPROVAL 徐燦霖

REVISION

DATE

DATE

DATE

DATE

DIMENSIONS ARE IN MILLIMETERS

UNLESS OTHERWISE SPECIFIED TOLERANCE

0.5-5=±0.2 120-315=±1

5-30=±0.4 315-1000=±1.6

30-120=±0.6 1000-2000=±2.4

SCALE 4:1 SIZE A

REVISION

DESCRIPTION ENGINEER

D

C

B

A

D

C

B

A

4

3

2

1