

NO	DESCRIPTION	MATERIAL	Q'TY	FINISH	REMARK
1	PIN	BRASS	1	GOLD	P-MCCD0180-G
2	INSULATION	TEFLON	1	TEFLON	I-0141T
3	BODY 1	BE CU	1	GOLD	B-MCCD0300-G
4	BODY 2	BRASS	1	NICKEL	B-MCCD0302-N
5	WASHER	BRASS	1	NICKEL	W-0038-N
6	INSULATION	TEFLON	1	TEFLON	I-0146T
7	RING	BRASS	NICKEL	R-0038-G	

D

C

B

A

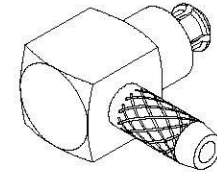
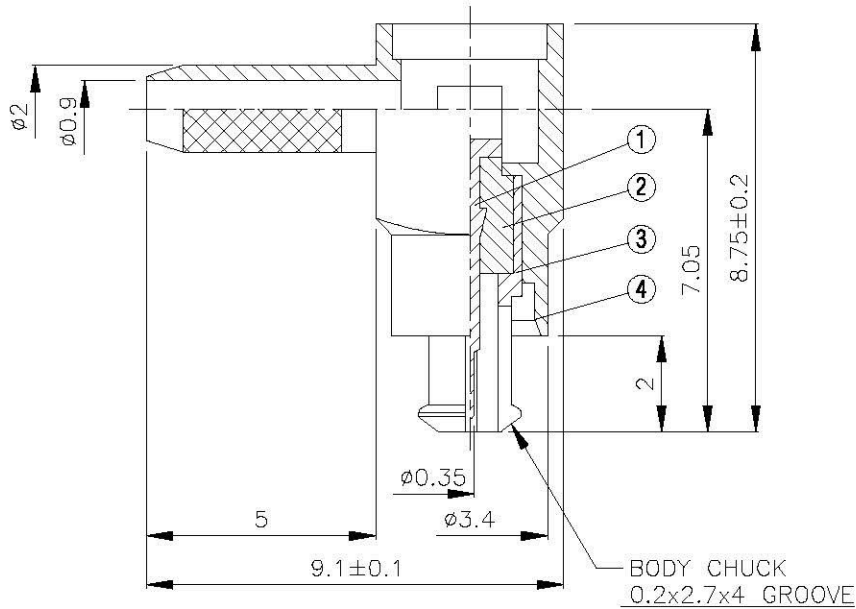
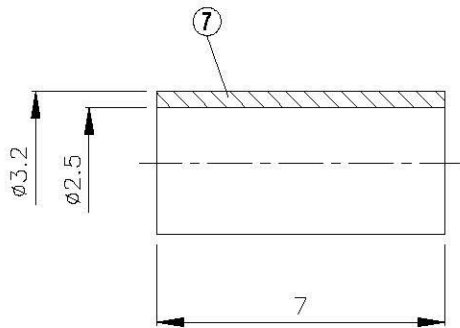

D

C

B

A

	All Connectors <small>www.allconnectors.com info@allconnectors.com Tel: 0049 711 2094700 Fax: 0049 711 2094700 47844 Hildesheim, Germany info@allconnectors.de</small>	DRAWN MARY DATE 91.10.22 CHECKED 黄巧君 DATE 96.01.24 Q.A. 蘇姿潔 DATE APPROVAL 徐燦霖 DATE REVISION DATE	DIMENSIONS ARE IN MILLIMETERS UNLESS OTHERWISE SPECIFIED TOLERANCE 0.5-5=±0.2 120-315=±1 5-30=±0.4 315-1000=±1.6 30-120±0.6 1000-2000=±2.4			REVISION DESCRIPTION ENGINEER	
	TITLE MC-CARD MALE ANGLE CRIMP FOR RG 178/U	SCALE 4:1 SIZE A					
	PART NO. MCCD-03MV1-TGN						
	DRAWING NO. MCCD 03MV1 TGN						

4

3

2

1