

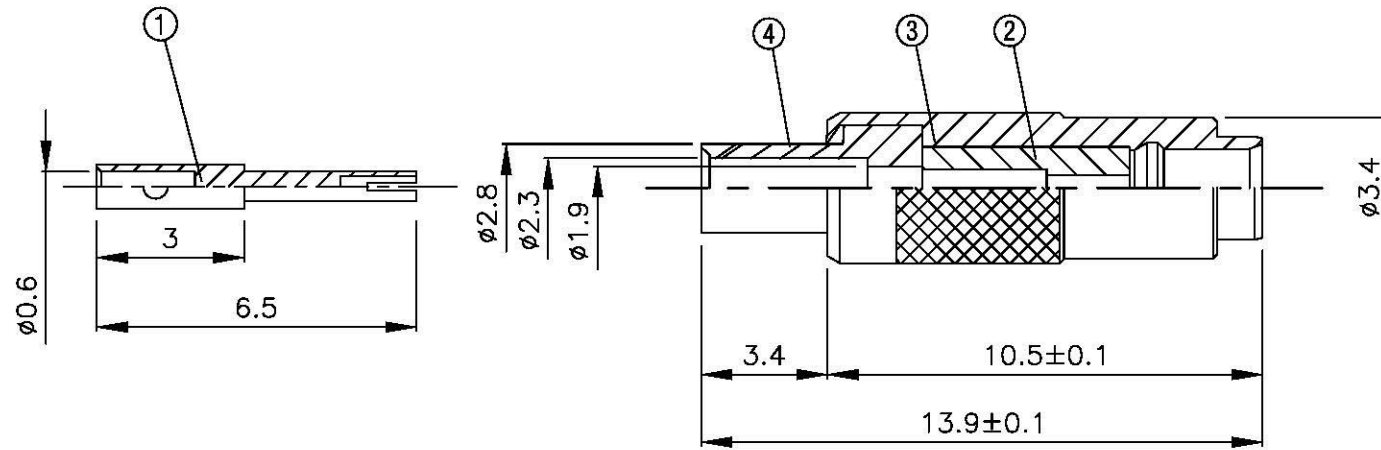

NO	DESCRIPTION	MATERIAL	Q'TY	FINISH	REMARK
1	PIN	BE CU	1	GOLD	P-MCCD0793-G
2	INSULATION	TEFLON	1	TEFLON	I-0157T
3	BODY 1	BRASS	1	NICKEL	B-MCCD1136-N
4	BODY 2	BRASS	1	GOLD	B-MMCX0112-G

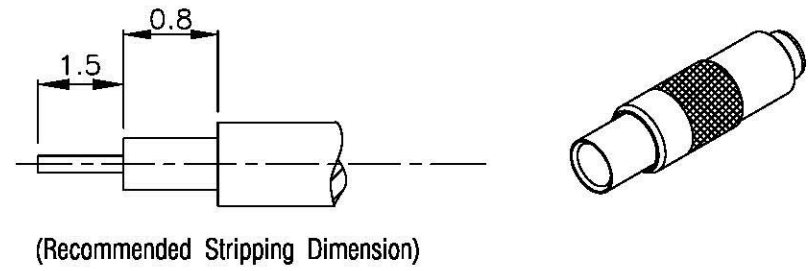
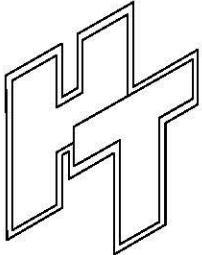

		DRAWN MARY DATE 95.12.01	DIMENSIONS ARE IN MILLIMETERS		REVISION		
	<small>www.allconnectors.de Tel.: 0049 711 7029304 Allconnectors GmbH, Germany</small>	<small>Info@allconnectors.de Fax: 0049 711 7029304 Kottbusstraße 22</small>	CHECKED 黄巧君 DATE 95.12.01	UNLESS OTHERWISE SPECIFIED TOLERANCE		DESCRIPTION	ENGINEER
	TITLE MC CARD FEMALE SOLDER FOR RG-405/U(.085")		Q.A. 蘇姿潔 DATE	0.5-5=±0.2 5-30=±0.4 30-120±0.6	120-315=±1 315-1000=±1.6 1000-2000=±2.4		
	PART NO. MCCD-02V1-TGN		APPROVAL 徐燦霖 DATE	SCALE 4:1	SIZE A		
	DRAWING NO. MCCD 02V1 TGN		REVISION DATE				