

NO	DESCRIPTION	MATERIAL	Q'TY	FINISH	REMARK
1	PIN	BE CU	1	GOLD	P-MCCD0793-G
2	INSULATION	TEFLON	1	TEFLON	I-0157T
3	BODY 1	BRASS	1	NICKEL	B-MCCD1136-N
4	BODY 2	BRASS	1	NICKEL	B-MMCX0019-N
5	RING	BRASS	1	NICKEL	R-0001-G

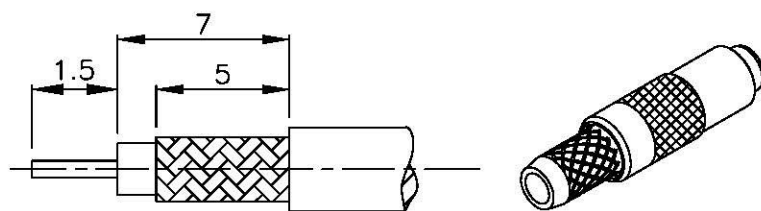

(Recommended Stripping Dimension)

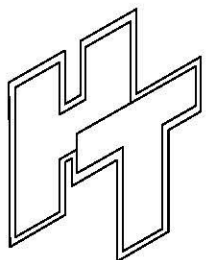
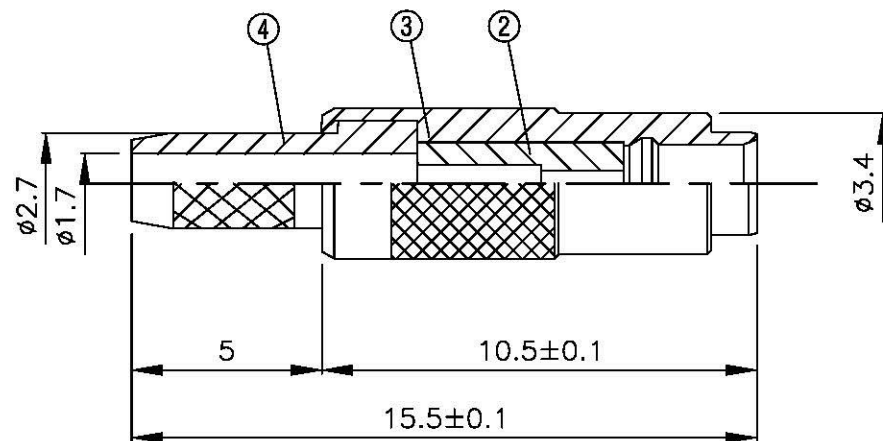
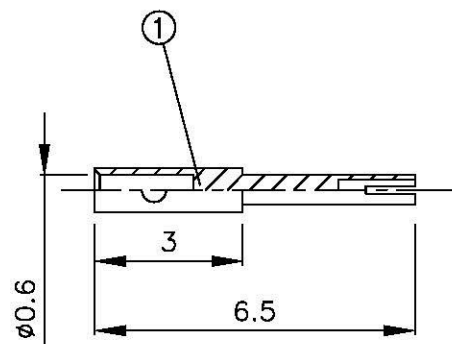
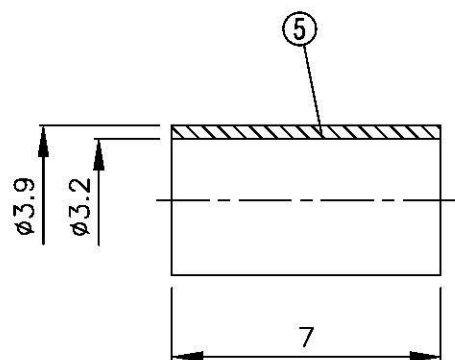

All Connectors

www.allconnectors.de
Tel.: 0049 733 300504
70794 Filzelsbach - Germany

info@allconnectors.de
Fax: 0049 733 300504
Kellernstr. 25

DRAWN MARY DATE 95.12.01

CHECKED 黃巧君 DATE 95.12.01

Q.A. 蘇姿潔 DATE

APPROVAL 徐燦霖 DATE

REVISION DATE

TITLE MC CARD FEMALE CRIMP FOR RG-316/U

PART NO. MCCD-02LV1-TGN

DRAWING NO. MCCD 02LV1 TGN

DIMENSIONS ARE IN MILLIMETERS

UNLESS OTHERWISE SPECIFIED TOLERANCE

0.5-5=±0.2 120-315=±1

5-30=±0.4 315-1000=±1.6

30-120±0.6 1000-2000=±2.4

SCALE 4:1 SIZE A

REVISION

DESCRIPTION	ENGINEER

D

D

C

C

B

B

A

A

4

3

2

1