

NO	DESCRIPTION	MATERIAL	Q'TY	FINISH	REMARK
1	PIN	PH.BRONZE	1	GOLD	P-MCCD0368-G
2	INSULATION	TEFLON	1	TEFLON	I-0157T
3	BODY 1	BRASS	1	NICKEL	B-MCCD0568-N
4	BODY 2	BE CU	1	GOLD	B-MCCD0300-G
5	RING	BRASS	NICKEL	R-0038-G	

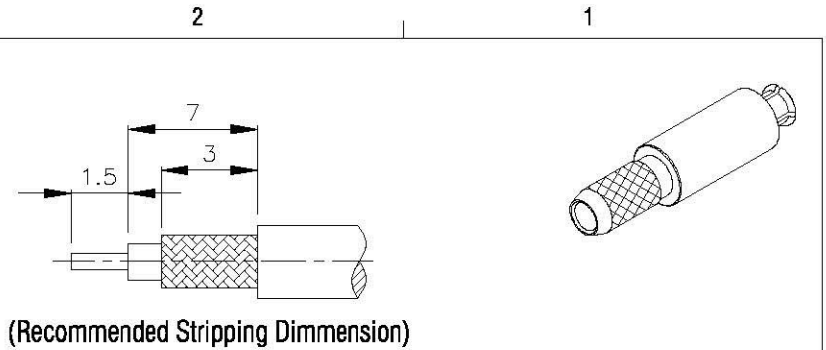

D
C
B
A

D
C
B
A

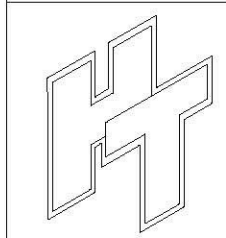
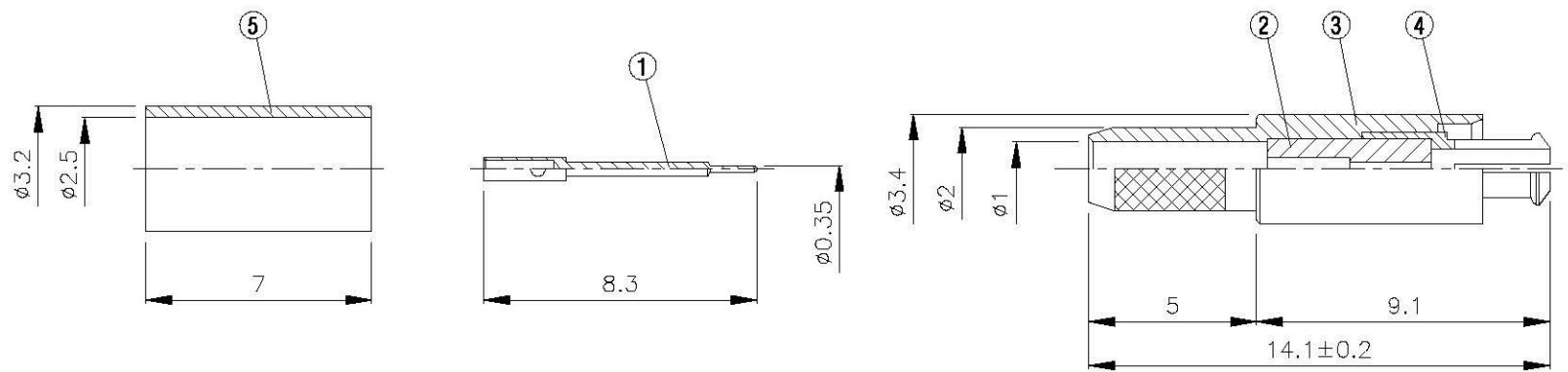

All Connectors
 www.allconnectors.com info@allconnectors.com
 70734 Filderstadt - Germany 70734 Filderstadt - Germany

TITLE **MC CARD MALE CRIMP FOR RG-178/U**

PART NO. **MCCD-01M-TGN**

DRAWING NO. **MCCD 01M TGN**

DRAWN **MARY** DATE **96.07.07**

CHECKED **蘇志欣** DATE

Q.A. **蘇姿潔** DATE

APPROVAL **徐燦霖** DATE

REVISION DATE

DIMENSIONS ARE IN MILLIMETERS

UNLESS OTHERWISE SPECIFIED TOLERANCE

0.5-5=±0.2	120-315=±1
5-30=±0.4	315-1000=±1.6
30-120=±0.6	1000-2000=±2.4

SCALE **4:1** SIZE **A**

REVISION	
DESCRIPTION	ENGINEER

4 3 2 1