

NO	DESCRIPTION	MATERIAL	Q'TY	FINISH	REMARK
1	BODY 1	PBT	1	PBT	B-FKR1350-F81
2	BODY 2	PBT	1	PBT	B-FKR1308
3	BODY 3	BRASS	1	NICKEL	B-SMA0674-N
4	INSULATION 1	TEFLON	1	TEFLON	I-0481T
5	BODY 3	BRASS	1	NICKEL	B-FKR1351-N
6	PIN	BE CU	1	GOLD	P-SMB0305-G
7	RING	BRASS	1	GOLD	R-0002-G
8	INSULATION 2	TEFLON	1	TEFLON	I-0136T
9	WASHER 2	BRASS	1	NICKEL	W-0023-N

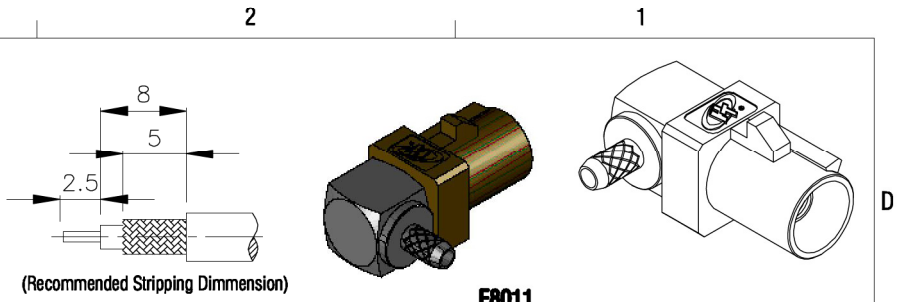

D

D

C

C

B

B

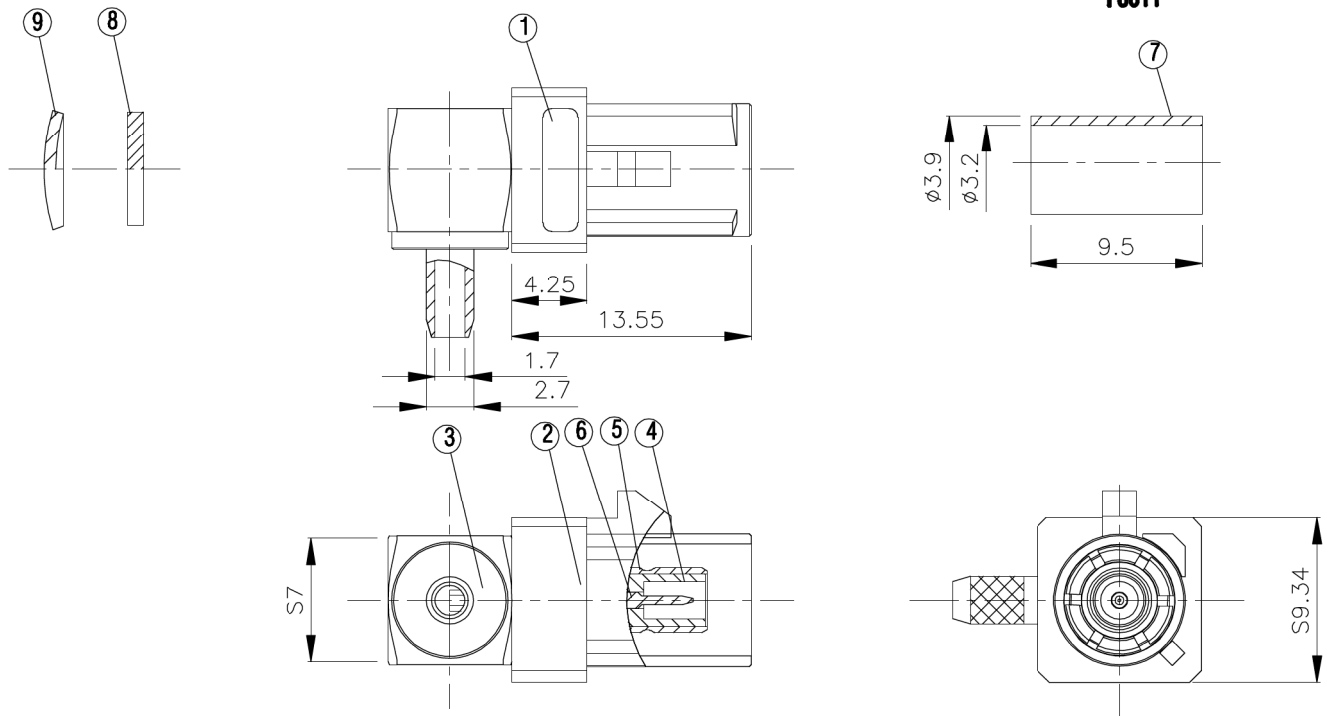

A

A

	<b>Allconnectors</b> <small>www.allconnectors.eu   info@allconnectors.eu          Tel. +49 (0)711 / 358 110 20   Fax +49 (0)711 / 358 110 25</small>	DRAWN	蘇姿潔	DATE	98.01.12	DIMENSIONS ARE IN MILLIMETERS		REVISION		
	TITLE	SMB FEMALE CRIMP TYPE RG-174/U RG-316/U	CHECKED	蘇志欣	DATE		UNLESS OTHERWISE SPECIFIED TOLERANCE		DESCRIPTION	ENGINEER
	PART NO.	FKR-04LV1-TGNPF	Q.A.	林妙樺	DATE		0.5-5=±0.2	120-315=±1		
	DRAWING NO.	FKR 04LV1 TGNPF	APPROVAL	徐燦霖	DATE		5-30=±0.4	315-1000=±1.6		
			REVISION		DATE		30-120=±0.6	1000-2000=±2.4		
						SCALE	4:1	SIZE	A	

4

3

2

1