

NO	DESCRIPTION	MATERIAL	Q'TY	FINISH	REMARK
1	BODY 1	PBT	1	PBT	B-FKR1348-K17
2	BODY 2	PBT		PBT	B-FKR1308
3	BODY 3	BRASS	1	GOLD	B-FKR1349-N
4	INSULATION 1	TEFLON	1	TEFLON	I-0663T
5	BODY 4	BRASS	1	NICKEL	B-FKR1410-N
6	PIN	BE CU	1	GOLD	P-FKR0986-G
7	WASHER 1	BE CU	1	GOLD	W-0035-G
8	RING	BRASS	1	GOLD	R-0007-G

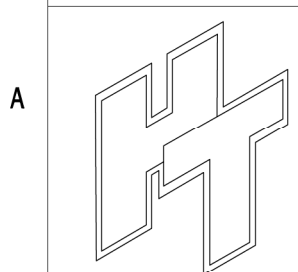
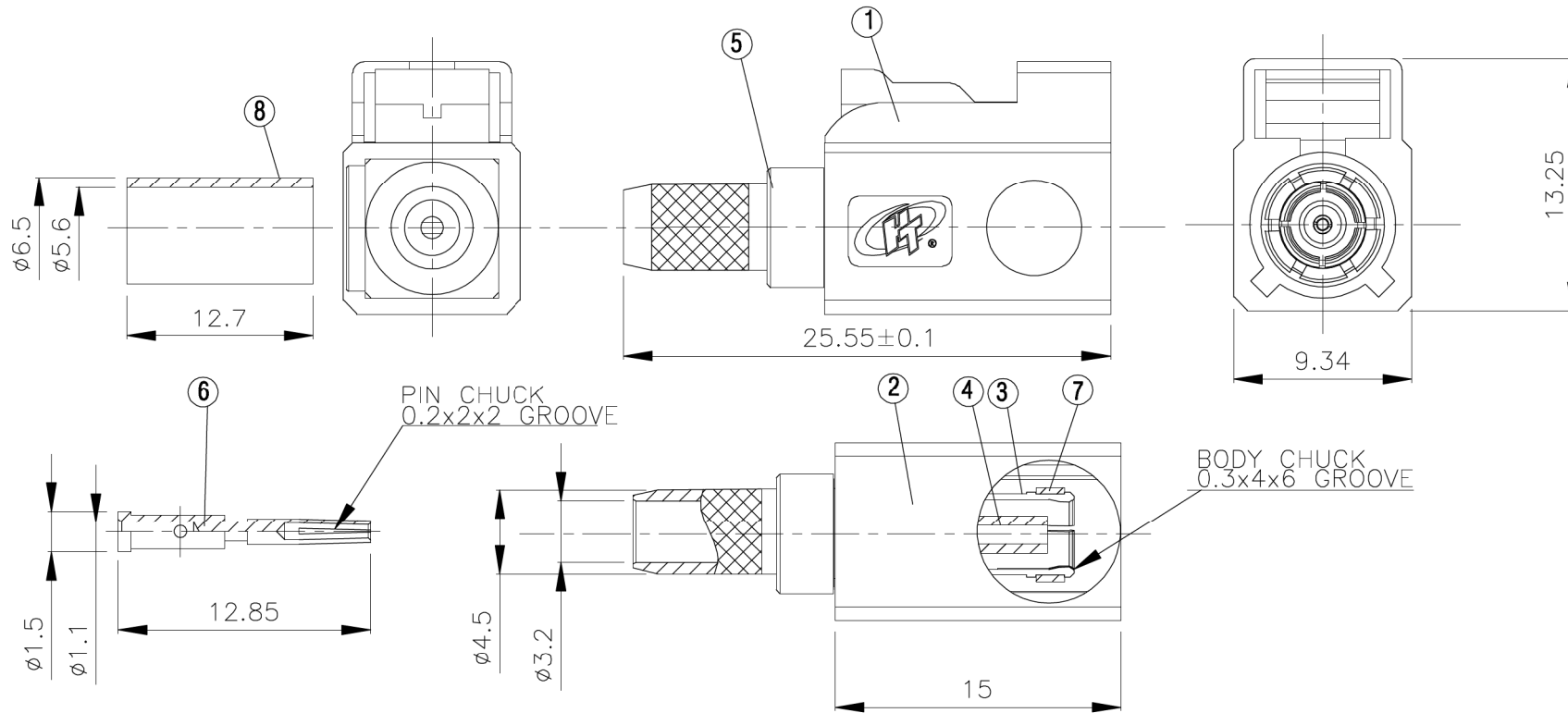
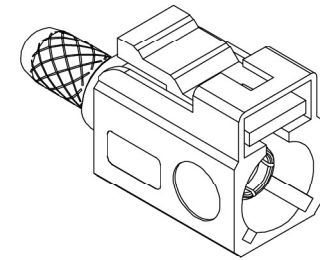
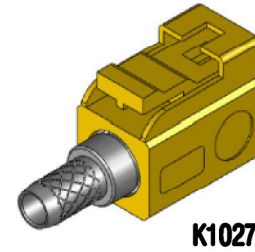
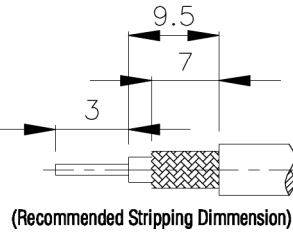

Allconnectors
www.allconnectors.eu | info@allconnectors.eu
Tel. +49 (0)711 / 358 110 20 | Fax +49 (0)711 / 358 110 25

TITLE **SMB FEMALE CRIMP FOR RG-58/U**

PART NO. **FKR-10F-TGGPK**

DRAWING NO. **FKR 10F TGGPK**

DRAWN	蘇姿潔	DATE	98.05.11
CHECKED	蘇志欣	DATE	
Q.A.	林妙樺	DATE	
APPROVAL	徐燦霖	DATE	
REVISION		DATE	

DIMENSIONS ARE IN MILLIMETERS

UNLESS OTHERWISE SPECIFIED TOLERANCE			
0.5-5=±0.2	120-315=±1		
5-30=±0.4	315-1000=±1.6		
30-120=±0.6	1000-2000=±2.4		

SCALE 4:1 SIZE A

REVISION		
DESCRIPTION	ENGINEER	