

NO	DESCRIPTION	MATERIAL	Q'TY	FINISH	REMARK
1	BODY 1	PBT	1	PBT	B-FKR1348-B91
2	BODY 2	PBT		PBT	B-FKR1308
3	BODY 3	BRASS	1	GOLD	B-FKR1349-N
4	INSULATION 1	TEFLON	1	TEFLON	I-0663T
5	BODY 4	BRASS	1	NICKEL	B-FKR1410-N
6	PIN	BE CU	1	GOLD	P-FKR0986-G
7	WASHER 1	BE CU	1	GOLD	W-0035-G
8	RING	BRASS	1	GOLD	R-0007-G

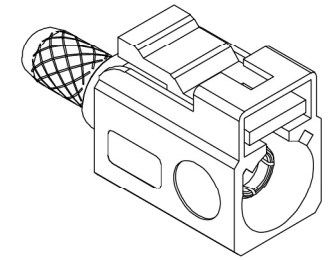

B9001

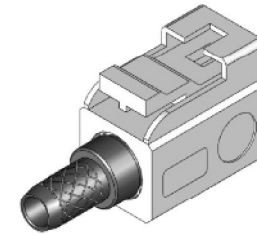
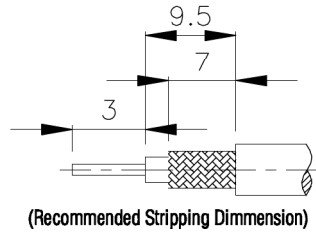
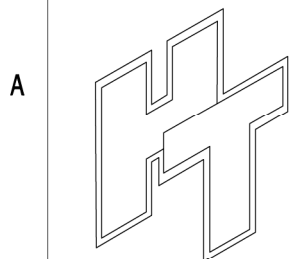
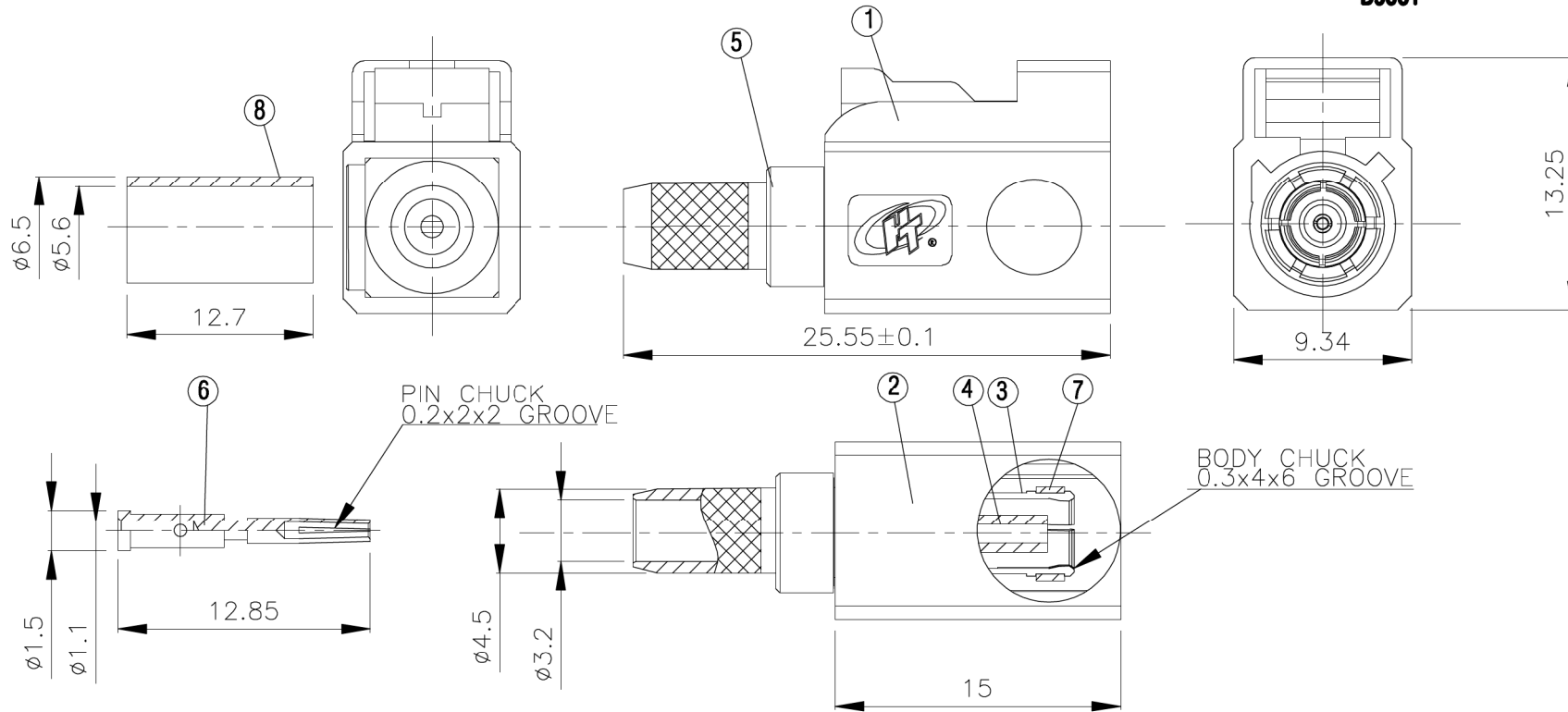

Allconnectors

www.allconnectors.eu | info@allconnectors.eu
Tel. +49 (0)711 / 358 110 20 | Fax +49 (0)711 / 358 110 25

TITLE **SMB FEMALE CRIMP
TYPE RG-58/U**

PART NO. **FKR-10F-TGNPB**

DRAWING NO. **FKR 10F TGNPB**

DRAWN **蘇姿潔** DATE **98.05.11**

CHECKED **蘇志欣** DATE

Q.A. **林妙樺** DATE

APPROVAL **徐燦霖** DATE

REVISION DATE

DIMENSIONS ARE IN MILLIMETERS

UNLESS OTHERWISE SPECIFIED
TOLERANCE

0.5-5=±0.2 120-315=±1

5-30=±0.4 315-1000=±1.6

30-120±0.6 1000-2000=±2.4

SCALE 4:1 SIZE A

REVISION

DESCRIPTION ENGINEER

A

A

4

3

2

1