

NO	DESCRIPTION	MATERIAL	Q'TY	FINISH	REMARK
1	BODY 1	PBT	1	PBT	B-FKR1348-I11
2	BODY 2	PBT		PBT	B-FKR1308
3	BODY 3	BRASS	1	GOLD	B-FKR1349-N
4	INSULATION 1	TEFLON	1	TEFLON	I-0472T
5	BODY 4	BRASS	1	NICKEL	B-SMB0674-N
6	PIN	BE CU	1	GOLD	P-SMB0302-G
7	WASHER 1	BE CU	1	GOLD	W-0035
8	RING	BRASS	1	GOLD	R-0002-G
9	INSULATION 2	TEFLON	1	TEFLON	I-0146T
10	WASHER 2	BRASS	1	NICKEL	W-0057-N

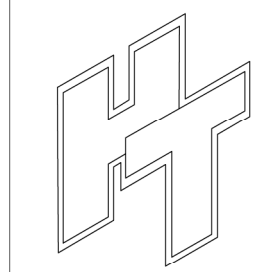
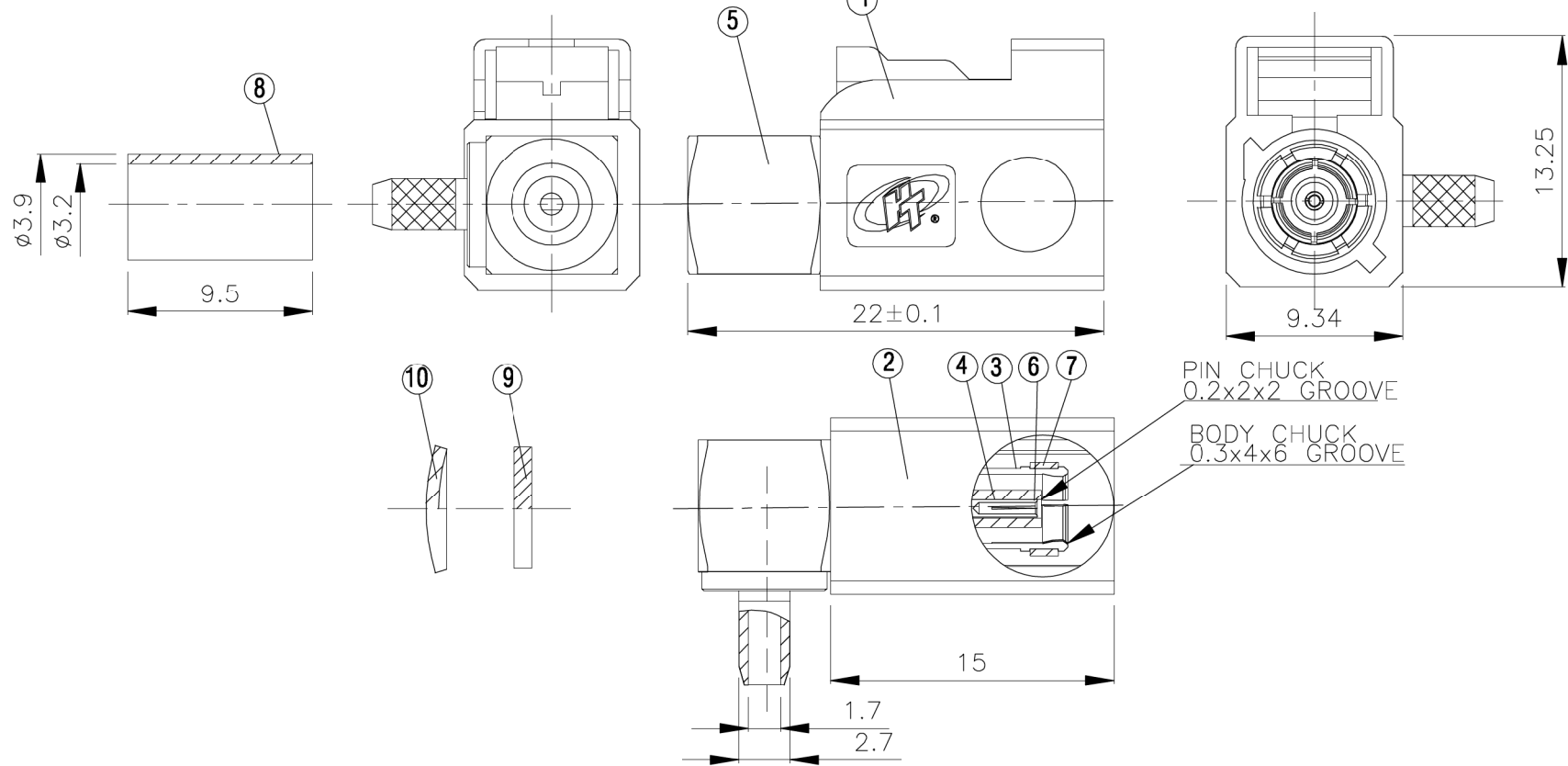
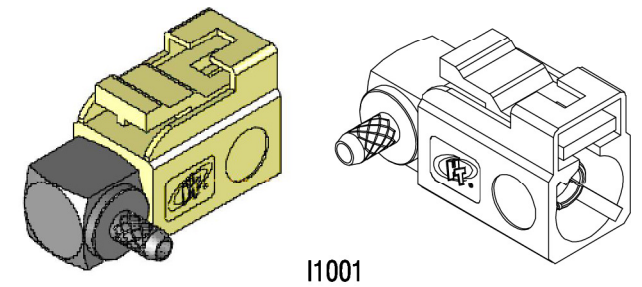
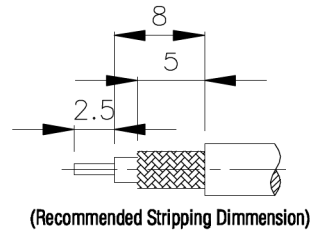

Allconnectors www.allconnectors.eu info@allconnectors.eu Tel. +49 (0)711 / 358 110 20 Fax +49 (0)711 / 358 110 25	
TITLE	SMB FEMALE CRIMP TYPE RG-174/U RG-316/U
PART NO.	FKR-03LV1-TGNPI
DRAWING NO.	FKR 03LV1 TGNPI

DRAWN	蘇姿潔	DATE	98.05.10
CHECKED	蘇志欣	DATE	
Q.A.	林妙樺	DATE	
APPROVAL	徐燦霖	DATE	
REVISION		DATE	

DIMENSIONS ARE IN MILLIMETERS			
UNLESS OTHERWISE SPECIFIED TOLERANCE			
0.5-5=±0.2	120-315=±1		
5-30=±0.4	315-1000=±1.6		
30-120=±0.6	1000-2000=±2.4		
SCALE	4:1	SIZE	A

REVISION	
DESCRIPTION	ENGINEER