

NO	DESCRIPTION	MATERIAL	Q'TY	FINISH	REMARK
1	BODY 1	PBT	1	PBT	B-FKR1348-F81
2	BODY 2	PBT		PBT	B-FKR1308
3	BODY 3	BRASS	1	GOLD	B-FKR1349-N
4	INSULATION 1	TEFLON	1	TEFLON	I-0472T
5	BODY 4	BRASS	1	NICKEL	B-SMB0589-N
6	PIN	BE CU	1	GOLD	P-SMB0933-G
7	WASHER 1	BE CU	1	GOLD	W-0035
8	RING	BRASS	1	GOLD	R-0007-G
9	INSULATION 2	TEFLON	1	TEFLON	I-0146T
10	WASHER 2	BRASS	1	NICKEL	W-0057-N

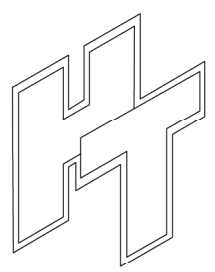
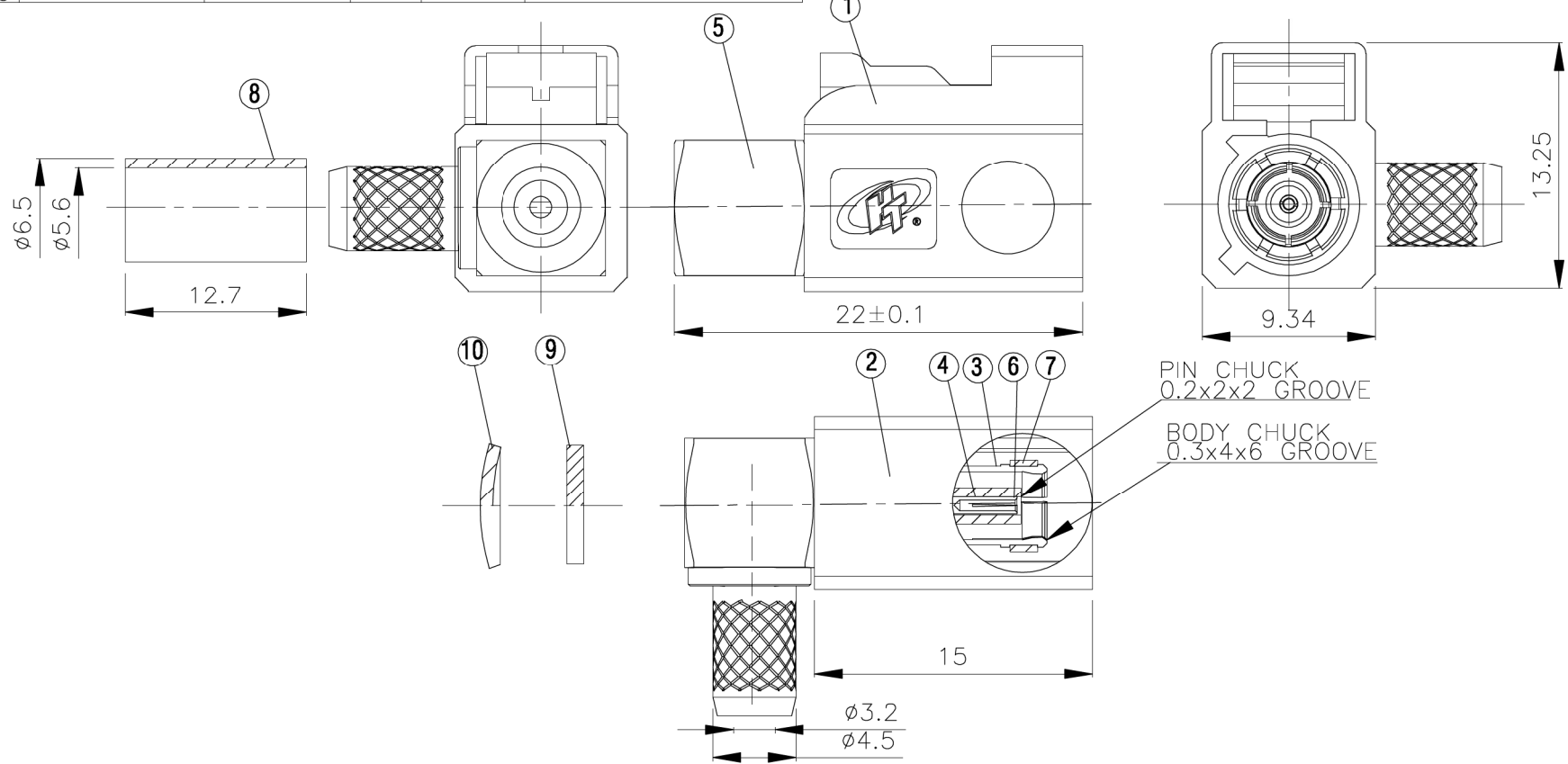
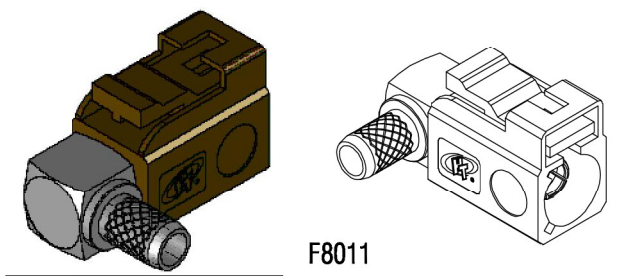
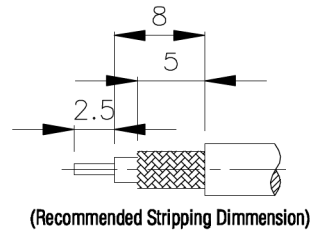

Allconnectors
 www.allconnectors.eu | info@allconnectors.eu
 Tel. +49 (0)711 / 358 110 20 | Fax +49 (0)711 / 358 110 25

TITLE **SMB FEMALE CRIMP TYPE RG-58/U**

PART NO. **FKR-03F-TGNPF**

DRAWING NO. **FKR 03F TGNPF**

DRAWN	蘇姿潔	DATE	98.05.10
CHECKED	蘇志欣	DATE	
Q.A.	林妙樺	DATE	
APPROVAL	徐燦霖	DATE	
REVISION		DATE	

DIMENSIONS ARE IN MILLIMETERS			
UNLESS OTHERWISE SPECIFIED TOLERANCE			
0.5-5=±0.2	120-315=±1		
5-30=±0.4	315-1000=±1.6		
30-120=±0.6	1000-2000=±2.4		
SCALE	4:1	SIZE	A

REVISION		
DESCRIPTION	ENGINEER	