

NO	DESCRIPTION	MATERIAL	Q'TY	FINISH	REMARK
1	BODY 1	PBT	1	PBT	B-FKR1348-E62
2	BODY 2	PBT		PBT	B-FKR1308
3	BODY 3	BRASS	1	GOLD	B-FKR1349-N
4	INSULATION 1	TEFLON	1	TEFLON	I-0472T
5	BODY 4	BRASS	1	NICKEL	B-SMB0589-N
6	PIN	BE CU	1	GOLD	P-SMB0933-G
7	WASHER 1	BE CU	1	GOLD	W-0035
8	RING	BRASS	1	GOLD	R-0007-G
9	INSULATION 2	TEFLON	1	TEFLON	I-0146T
10	WASHER 2	BRASS	1	NICKEL	W-0057-N

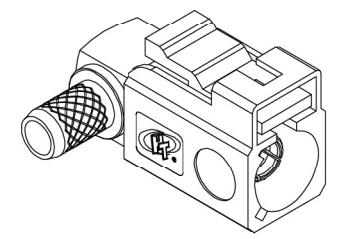

E6002

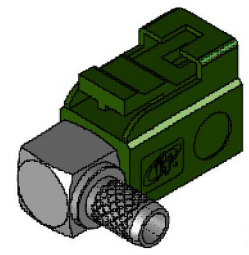
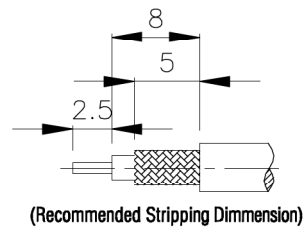
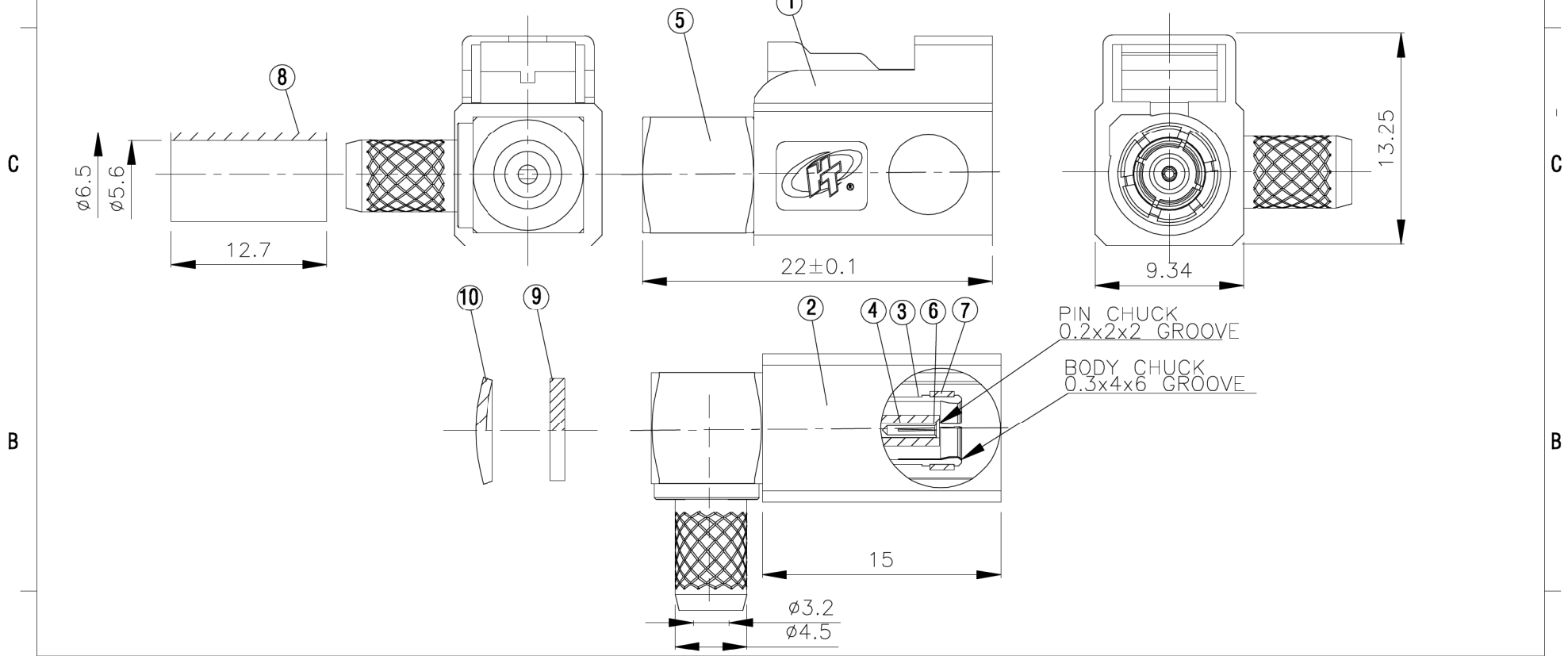

	 www.allconnectors.eu info@allconnectors.eu Tel. +49 (0)711 / 358 110 20 Fax +49 (0)711 / 358 110 25	DRAWN DATE 98.05.10	DIMENSIONS ARE IN MILLIMETERS		REVISION		
	TITLE	SMB FFMAI F CRIMP TYPE RG-58/U	CHECKED DATE	UNLESS OTHERWISE SPECIFIED TOLERANCE		DESCRIPTION	ENGINEER
	PART NO.	FKR-03F-TGNPE	Q.A. DATE	0.5-5=±0.2 120-315=±1			
	DRAWING NO.	FKR 03F TGNPE	APPROVAL DATE	5-30=±0.4 315-1000=±1.6			
			REVISION DATE	30-120±0.6 1000-2000=±2.4			
			SCALE 4:1 SIZE A				