

NO	DESCRIPTION	MATERIAL	Q'TY	FINISH
1	BODY	BRASS	1	NICKEL
2	CHASSIS	BRASS	1	NICKEL
3	PIN+BOBBIN	P.P+BOBBIN	1	TIN
4	INSULATION	DELTRIN	1	DELTRIN
5	PIN	BRASS	1	TIN

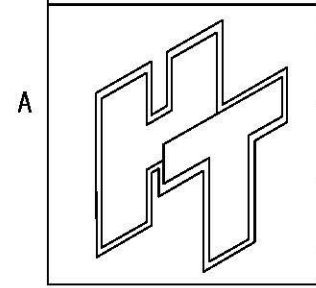
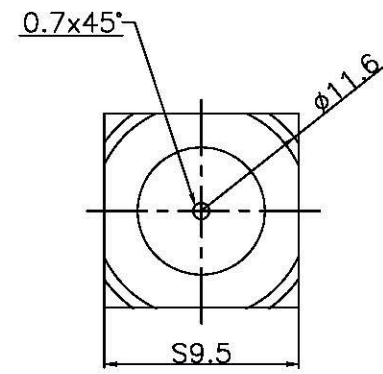
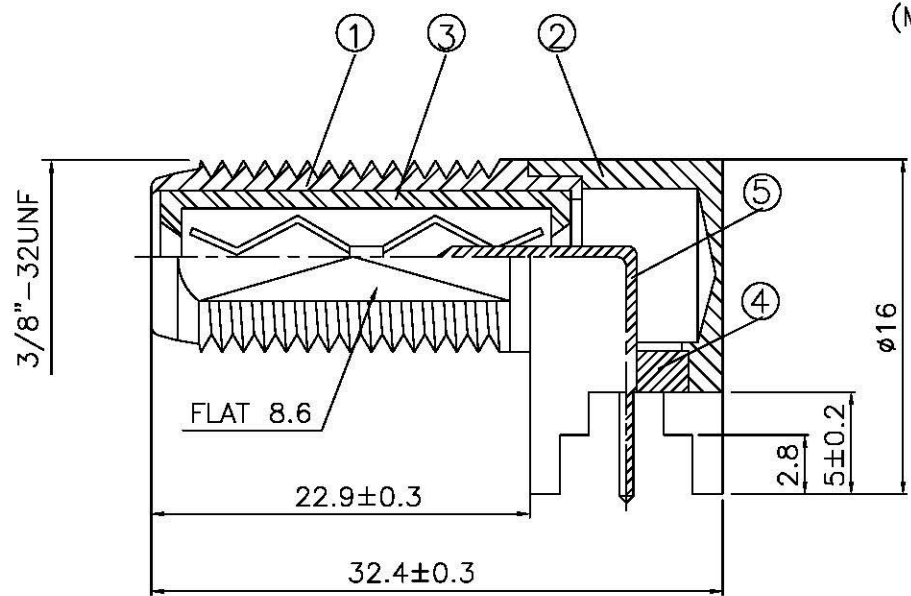
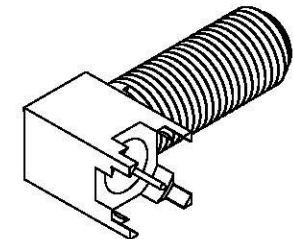
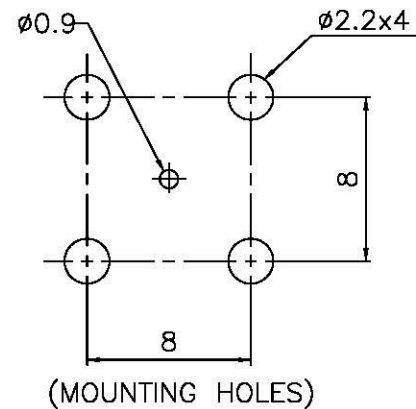

**All Connectors**  
 www.allconnectors.de info@allconnectors.de  
 Tel.: 04949 122 0700914 Fax: 04949 122 0700914  
 70794 FilzversLeut - Germany Kellenmersstr. 25

**TITLE** RIGHT ANGLE FEMALE  
PC MOUNT

**PART NO.** F-13V4-DTN

**DRAWING NO.** F-13V4-DTN

**DRAWN** MARY **DATE** 96.07.06

**CHECKED** 蘇志欣 **DATE**

**Q.A.** 蘇姿潔 **DATE**

**APPROVAL** 徐燦霖 **DATE**

**REVISION** **DATE**

**DIMENSIONS ARE IN MILLIMETERS**

**UNLESS OTHERWISE SPECIFIED TOLERANCE**

0.5-5=±0.2	120-315=±1
5-30=±0.4	315-1000=±1.6
30-120=±0.6	1000-2000=±2.4

**SCALE** 4:1 **SIZE** A

REVISION	
DESCRIPTION	ENGINEER