

NO	DESCRIPTION	MATERIAL	Q'TY	FINISH
1	BODY 1	DIE-CAST	1	NICKEL
2	BODY 2	BRASS	1	NICKEL
3	INSULATION	DELTRIN	1	DELTRIN
4	GASKET	SI RUBBER	1	RUBBER
5	WASHER 1	BRASS	1	NICKEL
6	SPRING	BRASS	1	NICKLE
7	WASHER 2	BRASS	1	NICKEL
8	PIN	BRASS	1	GOLD
9	INSULATION	DELTRIN	1	DELTRIN

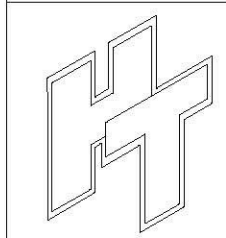
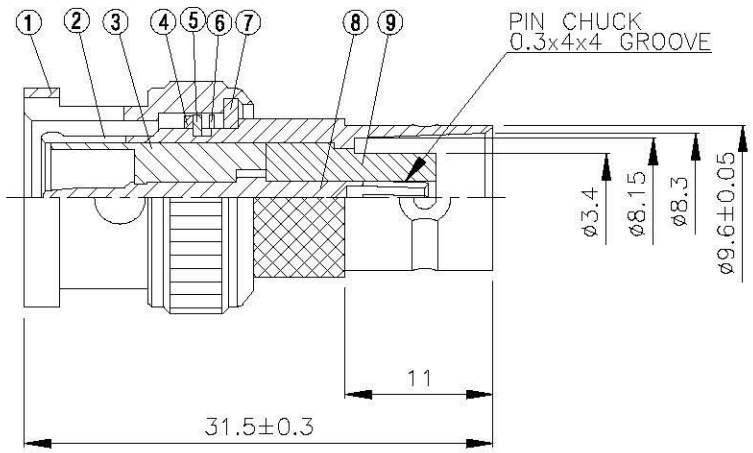
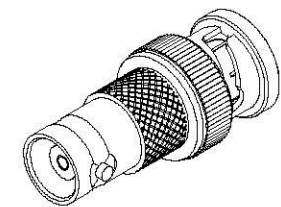

Allconnectors
 www.allconnectors.de
 Tel.: 0049 211 406202
 40784 Niekerstadt - Germany

Info@allconnectors.de
 Fax: 0049 211 406204
 Kette Nr. 107, 23

TITLE
BNC MALE -FEMALE ADAPTOR

PART NO.
BNC-47-DGN

DRAWING NO.
BNC 47 DGN

DRAWN MARY **DATE** 06.06.18

CHECKED 蘇志欣 **DATE**

Q.A. 蘇姿潔 **DATE**

APPROVAL 徐燦霖 **DATE**

REVISION **DATE**

DIMENSIONS ARE IN MILLIMETERS

UNLESS OTHERWISE SPECIFIED TOLERANCE

0.5-5=±0.2	120-315=±1
5-30=±0.4	315-1000=±1.6
30-120±0.6	1000-2000=±2.4

SCALE 4:1 **SIZE** A

REVISION	
DESCRIPTION	ENGINEER