

NO	DESCRIPTION	MATERIAL	Q'TY	FINISH
1	SHELL	BRASS	1	NICKEL
2	BODYI	BRASS	1	NICKEL
3	INSULATION	DELRIN	1	DELRIN
4	GASKET	RUBBER	1	RUBBER
5	WASHER	BRASS	1	NICKEL
6	SPRING	SK-5	1	NICKEL
7	WASHER	BRASS	1	NICKEL
8	BODYII	BRASS	1	NICKEL
9	PIN	BRASS	2	GOLD
10	INSULATION	DELRIN	2	DELRIN
11	BODYIII	BRASS	2	NICKEL
12	RING	BRASS	2	NICKEL
13	PIN	BRASS	2	GOLD

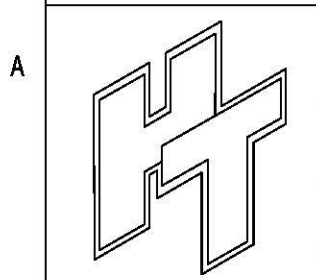
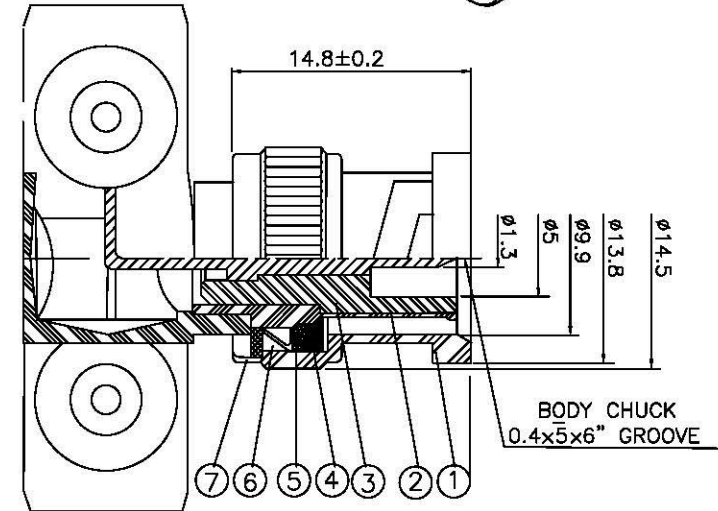
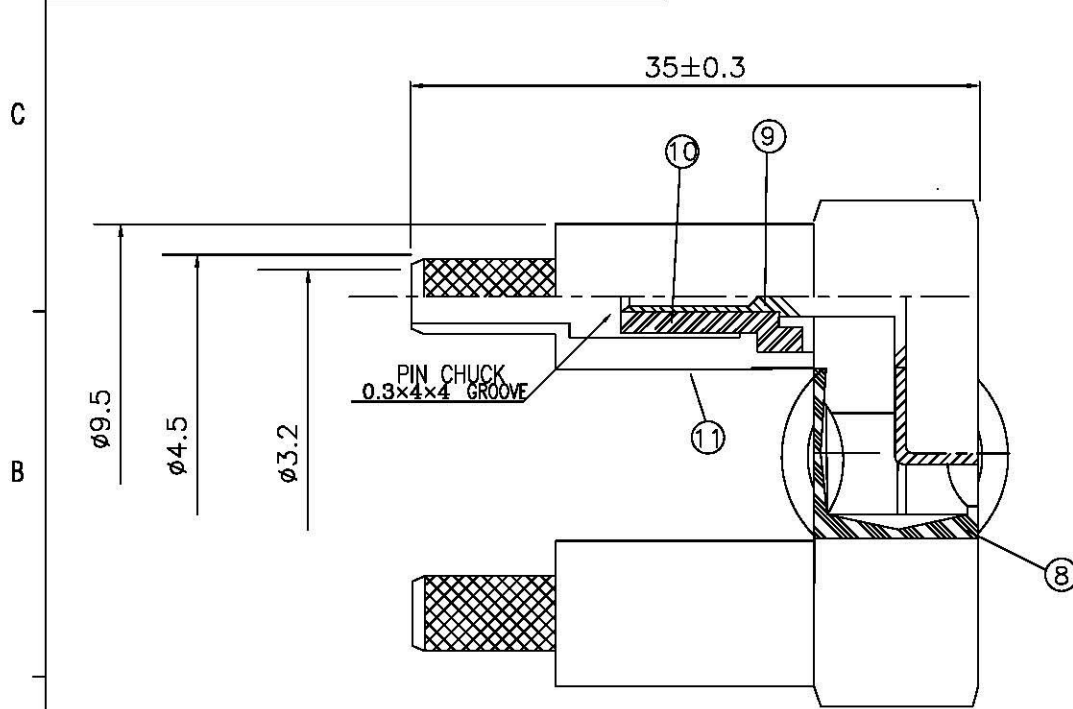
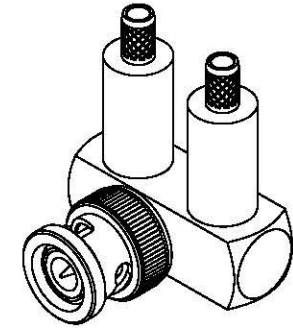
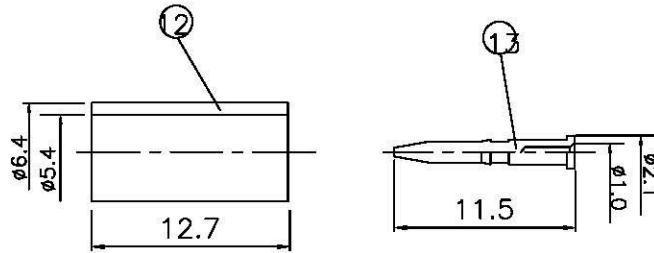

All Connectors
 www.allconnectors.de
 Tel: +49 711 709490
 A-92541 Hildersbach, Germany

INTO ALL CONNECTORS
 Fax: +49 711 709490
 Kottmeyerstr. 11

TITLE ANGLE MALE WITH DOUBLE CRIMP FOR RG58U, 141A/U

PART NO. BNC-44F-DGN

DRAWING NO. BNC 44F DGN

DRAWN MARY

CHECKED 蘇志欣

Q.A. 蘇姿潔

APPROVAL 徐燦霖

REVISION

DATE 96.06.18

DATE

DATE

DATE

DATE

DIMENSIONS ARE IN MILLIMETERS

UNLESS OTHERWISE SPECIFIED TOLERANCE

0.5-5=±0.2 120-315=±1

5-30=±0.4 315-1000=±1.6

30-120=±0.6 1000-2000=±2.4

SCALE 3:1 SIZE A

REVISION	
DESCRIPTION	ENGINEER