

NO	DESCRIPTION	MATERIAL	Q'TY	FINISH
1	SHELL	BRASS	1	NICKEL
2	BODYI	BRASS	1	NICKEL
3	INSULATION	DELRIN	1	DELRIN
4	GASKET	RUBBER	1	RUBBER
5	WASHER	BRASS	1	NICKEL
6	SPRING	SK-5	1	NICKEL
7	WASHER	BRASS	1	NICKEL
8	BODYII	BRASS	1	NICKEL
9	PIN	BRASS	2	GOLD
10	INSULATION	DELRIN	2	DELRIN
11	BODYIII	BRASS	2	NICKEL

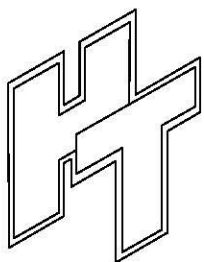
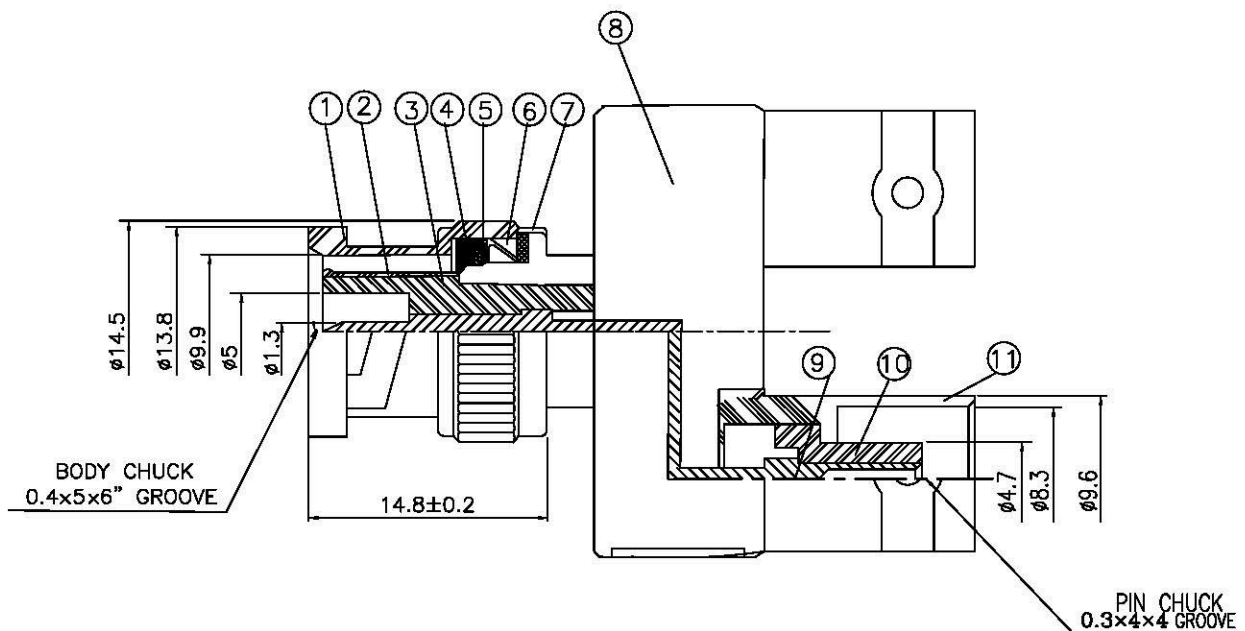
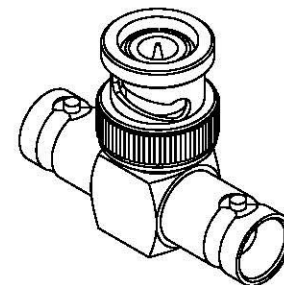

**Allconnectors**

www.allconnectors.de  
 Tel.: 0049 711 7009503  
 70794 Filzschmitt, Germany

Info@allconnectors.de  
 Fax: 0049 711 7009504  
 Kettnerstr. 25

TITLE  
**BNC DOUBLE FEMALE-MALE**

PART NO.  
**BNC-42-DGN**

DRAWING NO. **BNC 42 DGN**

DRAWN **MARY** DATE **96.06.18**

CHECKED **蘇志欣** DATE

Q.A. **蘇姿潔** DATE

APPROVAL **徐燦霖** DATE

REVISION DATE

DIMENSIONS ARE IN MILLIMETERS

UNLESS OTHERWISE SPECIFIED  
 TOLERANCE

0.5-5=±0.2 120-315=±1  
 5-30=±0.4 315-1000=±1.6  
 30-120=±0.6 1000-2000=±2.4

SCALE **3:1** SIZE **A**

REVISION

DESCRIPTION ENGINEER