

NO	DESCRIPTION	MATERIAL	Q'TY	FINISH
1	SHELL	BRASS	1	NICKEL
2	BODYI	BRASS	1	NICKEL
3	INSULATION	DELRIN	1	DELRIN
4	GASKET	RUBBER	1	RUBBER
5	WASHER	BRASS	1	NICKEL
6	SPRING	SK-5	1	NICKEL
7	WASHER	BRASS	1	NICKEL
8	BODYII	BRASS	1	NICKEL
9	PIN	BRASS	2	GOLD
10	INSULATION	DELRIN	2	DELRIN
11	BODYIII	BRASS	2	NICKEL
12	RING	BRASS	2	NICKEL
13	PIN	BRASS	2	GOLD

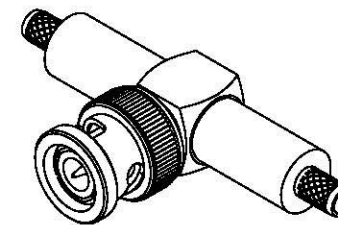
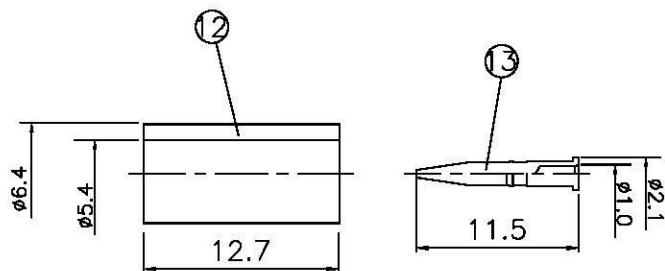

D

D

C

C

B

B

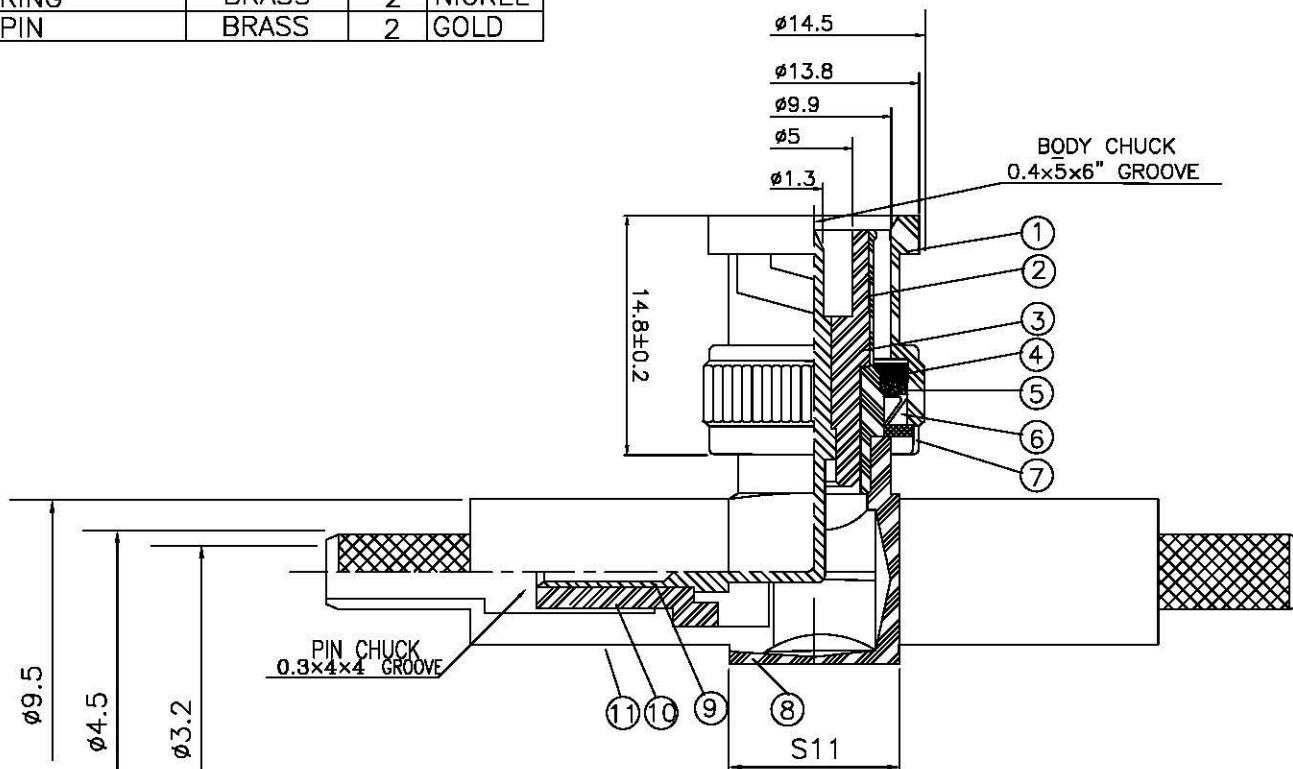

A

A

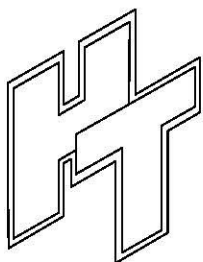

Allconnectors

www.allconnectors.de
 info@allconnectors.de
 70784 Filzschmitt, Germany
 Tel: +49 7141 20090-11
 Fax: +49 7141 20090-10
 Kottumerstr. 22

TITLE **BNC MALE WITH DOUBLE CRIMP FOR RG58U,141A/U**

PART NO. **BNC-41F-DGN**

DRAWING NO. **BNC 41F DGN**

DRAWN **MARY** DATE **96.06.18**

CHECKED **蘇志欣** DATE

Q.A. **蘇姿潔** DATE

APPROVAL **徐燦霖** DATE

REVISION DATE

DIMENSIONS ARE IN MILLIMETERS

UNLESS OTHERWISE SPECIFIED TOLERANCE

0.5-5=±0.2	120-315=±1
5-30=±0.4	315-1000=±1.6
30-120=±0.6	1000-2000=±2.4

SCALE **3:1** SIZE **A**

REVISION

DESCRIPTION	ENGINEER

4

3

2

1