

NO	DESCRIPTION	MATERIAL	Q'TY	FINISH
1	BODY	ZINC	1	NICKEL
2	PIN (FEMALE)	BRASS	2	GOLD
3	PIN (MALE)	BRASS	1	GOLD
4	WASHER	BRASS	1	NICKEL
5	INSULATION	DELRIN	2	DELRIN
6	INSULATION	DELRIN	1	DELRIN
7	SHELL	ABS	1	ABS
8	OUTER PIN	BRASS	1	NICKEL
9	SHELL	ZINC	1	NICKEL
10	GASKET	RUBBER	1	RUBBER
11	WASHER	SK-5	1	NICKEL
12	WASHER	BRASS	1	NICKEL
13	JACKET	PVC	1	PVC
14	BODY CAP	ZINC	1	NICKEL

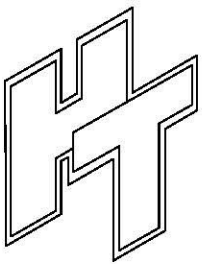
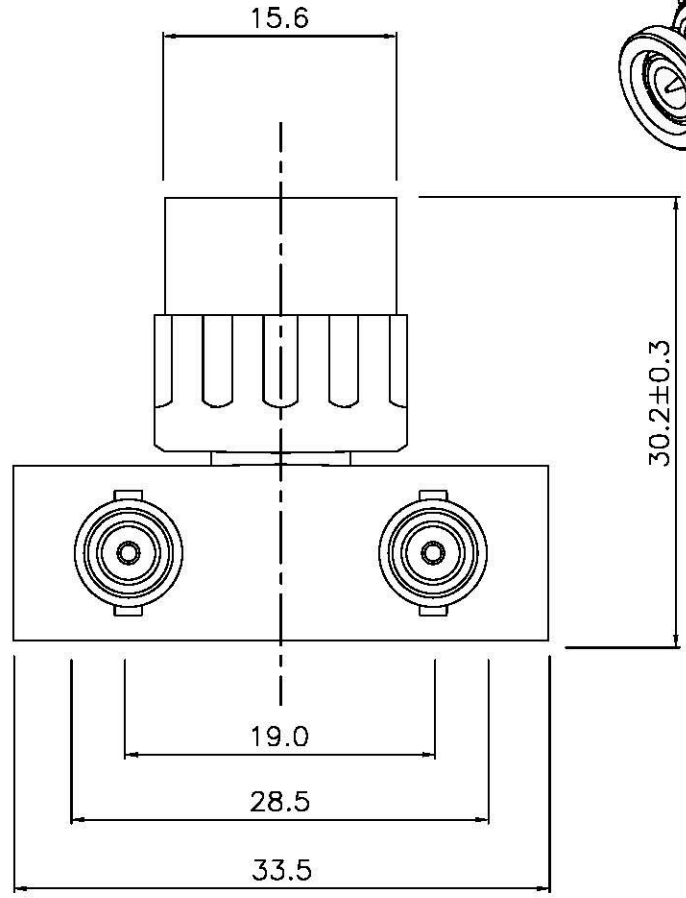
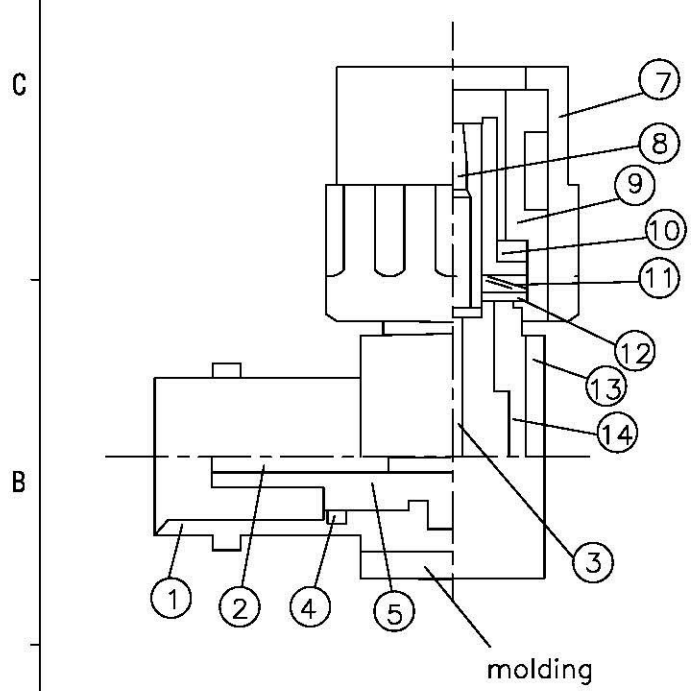
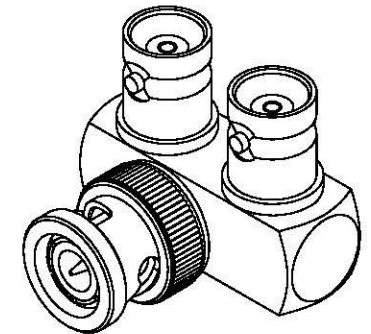

All Connectors
 www.allconnectors.de
 Tel.: 0333 711 705500
 70754 Ellersdorf, Germany
 info@allconnectors.de
 Fax: 0333 711 705504
 Kettweg 25

TITLE
ANGLE DOUBLE FEMALE-MALE

PART NO.
BNC-38-DGN

DRAWING NO. **BNC 38 DGN**

DRAWN	MARY	DATE	96.06.18
CHECKED	蘇志欣	DATE	
Q.A.	蘇姿潔	DATE	
APPROVAL	徐燦霖	DATE	
REVISION		DATE	

DIMENSIONS ARE IN MILLIMETERS			
UNLESS OTHERWISE SPECIFIED TOLERANCE			
0.5-5=±0.2	120-315=±1		
5-30=±0.4	315-1000=±1.6		
30-120=±0.6	1000-2000=±2.4		
SCALE	3:1	SIZE	A

REVISION	
DESCRIPTION	ENGINEER