

NO	DESCRIPTION	MATERIAL	Q'TY	FINISH
1	BODY	BRASS	1	NICKEL
2	INSULATION	DELRIN	1	DELRIN
3	PIN	BRASS	1	NICKEL
4	SHELL	BRASS	1	NICKEL
5	WASHER	BRASS	1	NICKEL
6	SPRING	BRASS	1	NICKEL
7	WASHER	BRASS	1	NICKEL
8	GASKET	RUBBER	1	RUBBER

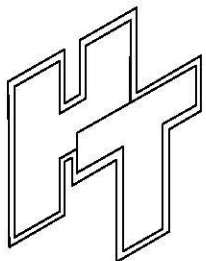
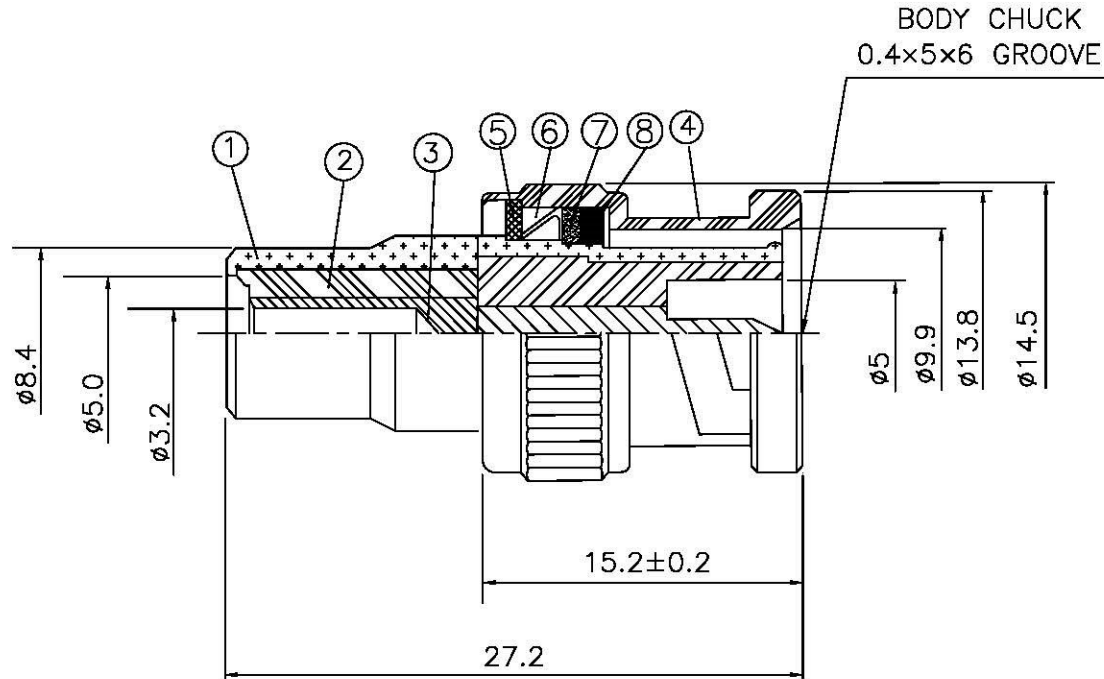
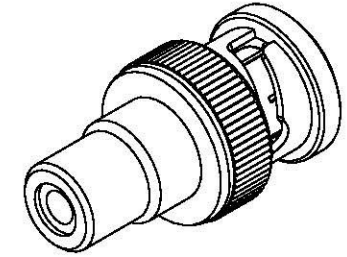

All Connectors

www.allconnectors.de
 info@allconnectors.de
 Tel: 0340 711 202402
 Fax: 0340 711 203044
 26754 Filzschroth Germany
 kette@connectors.de

TITLE
BNC MALE - RCA FEMALE

PART NO.
BNC-29-DNN

DRAWING NO. **BNC 29 DNN**

DRAWN **MARY** DATE **96.06.18**

CHECKED **蘇志欣** DATE

Q.A. **蘇姿潔** DATE

APPROVAL **徐燦霖** DATE

REVISION DATE

DIMENSIONS ARE IN MILLIMETERS

UNLESS OTHERWISE SPECIFIED TOLERANCE

0.5-5=±0.2 120-315=±1

5-30=±0.4 315-1000=±1.6

30-120=±0.6 1000-2000=±2.4

SCALE 4:1 SIZE A

REVISION

DESCRIPTION ENGINEER