

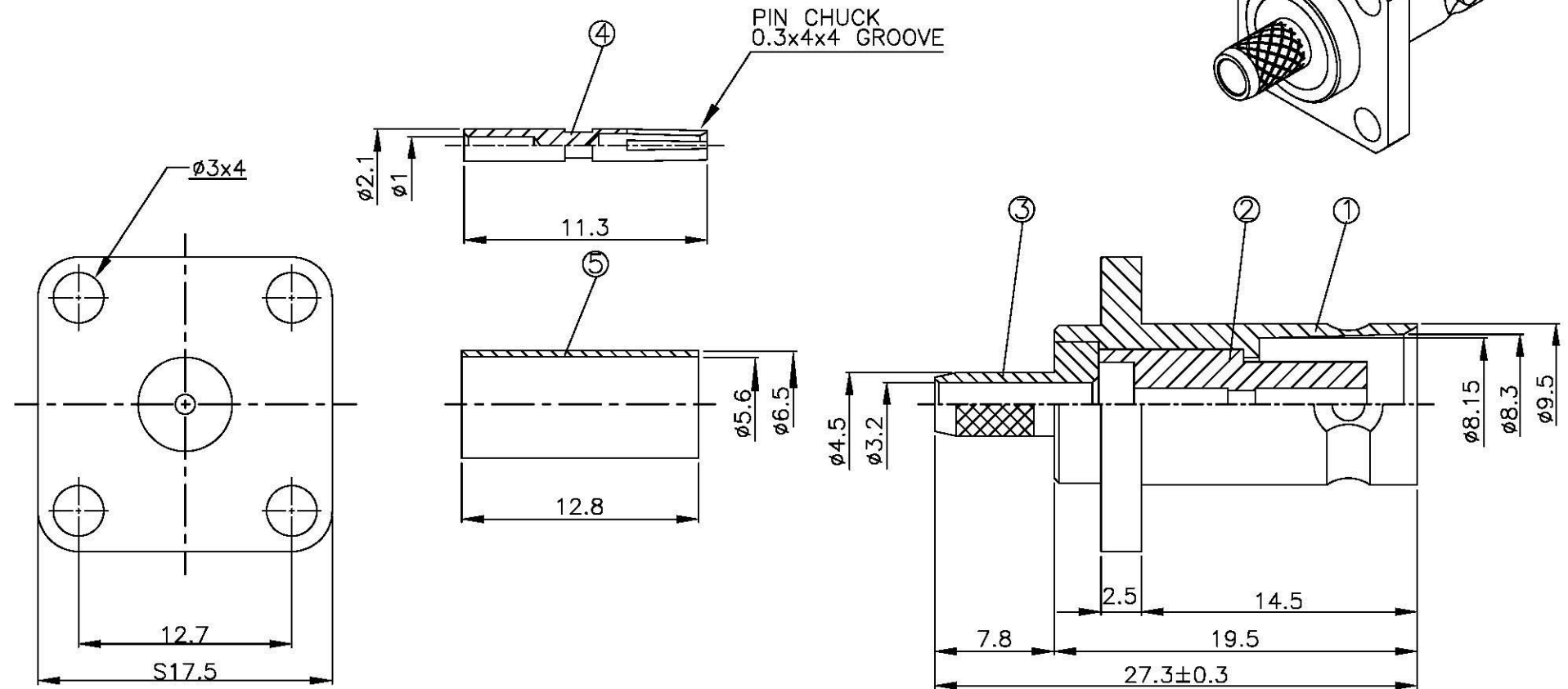

NO	DESCRIPTION	MATERIAL	Q'TY	FINISH	REMARK
1	BODY 1	BRASS	1	NICKEL	B-BNC0475-N
2	INSULATION	TEFLON	1	TEFLON	I-0231T
3	BODY 2	BRASS	1	GOLD	B-TNC0013-N
4	PIN	BRASS	1	NICKEL	P-TNC0054-G
5	RONG	BRASS	1	NICKEL	R-0007-N

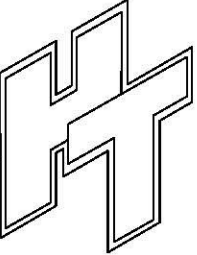

		DRAWN MARY DATE 96.06.18	DIMENSIONS ARE IN MILLIMETERS		REVISION		
	<small>www.allconnectors.de Tel.: 0049 714 700200 70794 Filzelsdorf - Germany</small>	<small>info@allconnectors.de Fax: 0049 714 700204 Kettnerstr. 25</small>	CHECKED 蘇志欣 DATE	UNLESS OTHERWISE SPECIFIED TOLERANCE		DESCRIPTION	ENGINEER
	TITLE BNC PANEL FEMALE CRIMP FOR RG 58/U		Q.A. 蘇姿潔 DATE	0.5-5=±0.2 120-315=±1			
	PART NO. BNC-14F-TGN		APPROVAL 徐燦霖 DATE	5-30=±0.4 315-1000=±1.6			
	DRAWING NO. BNC 14F TGN		REVISION DATE	30-120=±0.6 1000-2000=±2.4	SCALE 4:1	SIZE A	