

NO	DESCRIPTION	MATERIAL	Q'TY	FINISH	REMARK
1	BODY	BRASS	1	NICKEL	B-BNC0559-N
2	INSULATION	TEFLON	1	TEFLON	I-0044T
3	BODY	BRASS	1	NICKEL	B-BNC0115-N
4	GASKET	SI RUBBER	1	RUBBER	RU-0006
5	WASHER	BRASS	1	NICKEL	W-0001-N
6	NUT	BRASS	1	NICKEL	N-0003-N
7	PIN	BRASS	1	NICKEL	P-TNC0011-G

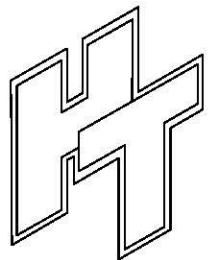
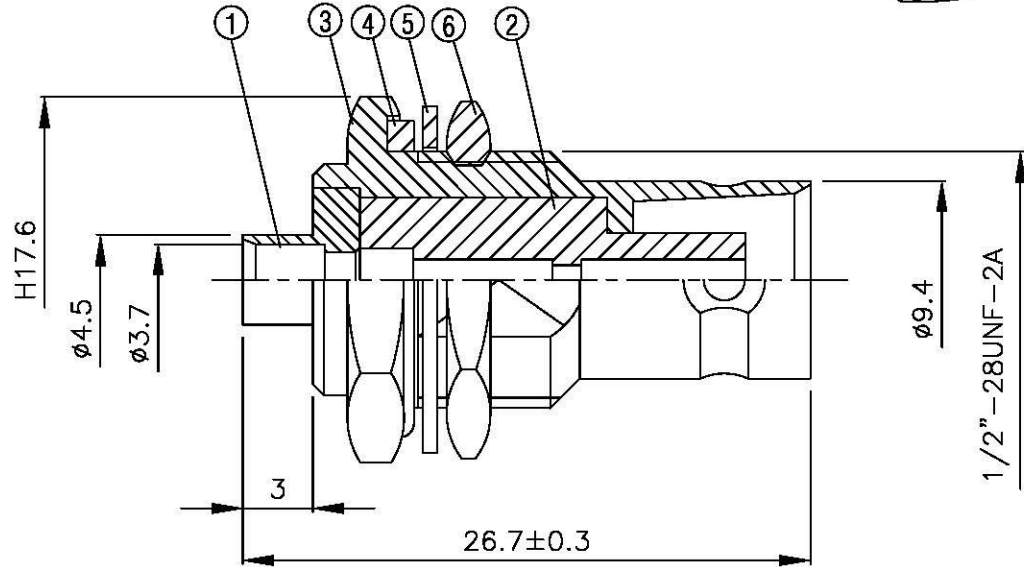
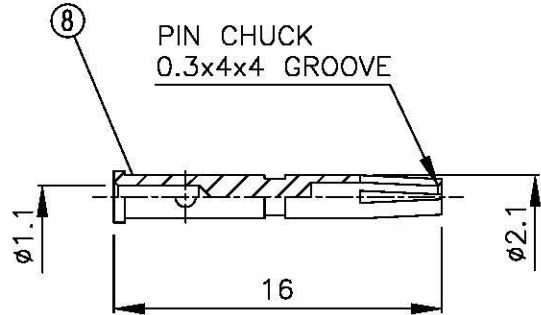
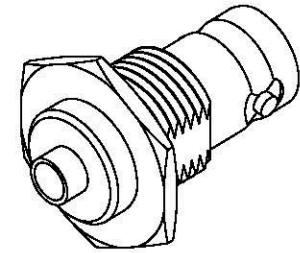
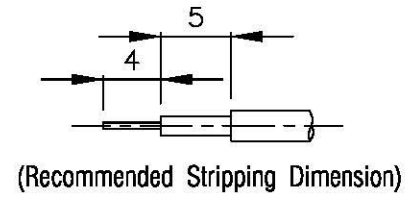

**All Connectors**

www.allconnectors.de  
Tel.: 0049 711 7008203  
76754 Filderstadt Germany

info@allconnectors.de  
Fax: 0049 711 7008204  
Kettenmstr. 25

TITLE **BNC FEMALE SOLDER FOR RG402 (.141)**

PART NO. **BNC-06V2-TGN**

DRAWING NO. **BNC 06V2 TGN**

DRAWN **MARY** DATE **96.06.28**

CHECKED **蘇志欣** DATE

Q.A. **蘇姿潔** DATE

APPROVAL **徐燦霖** DATE

REVISION DATE

DIMENSIONS ARE IN MILLIMETERS

UNLESS OTHERWISE SPECIFIED TOLERANCE

0.5-5=±0.2 120-315=±1

5-30=±0.4 315-1000=±1.6

30-120±0.6 1000-2000=±2.4

SCALE **4:1** SIZE **A**

REVISION

DESCRIPTION	ENGINEER