

| NO | DESCRIPTION | MATERIAL | Q'TY | FINISH | REMARK |
|----|-------------|-----------|------|--------|-------------|
| 1 | BODY | BRASS | 1 | NICKEL | B-TNC0929-N |
| 2 | INSULATION | TEFLON | 1 | TEFLON | I-0452T |
| 3 | BODY | BRASS | 1 | NICKEL | B-BNC0115-N |
| 4 | GASKET | SI RUBBER | 1 | RUBBER | RU-0006 |
| 5 | WASHER | BRASS | 1 | NICKEL | W-0001-N |
| 6 | NUT | BRASS | 1 | NICKEL | N-0003-N |
| 7 | PIN | BRASS | 1 | GOLD | P-TNC0652-G |
| 8 | PIN | BRASS | 1 | GOLD | P-FME0505-G |
| 9 | INSULATION | TEFLON | 1 | TEFLON | I-0256T |
| 10 | BODY | BRASS | 1 | GOLD | B-SMA0902-G |

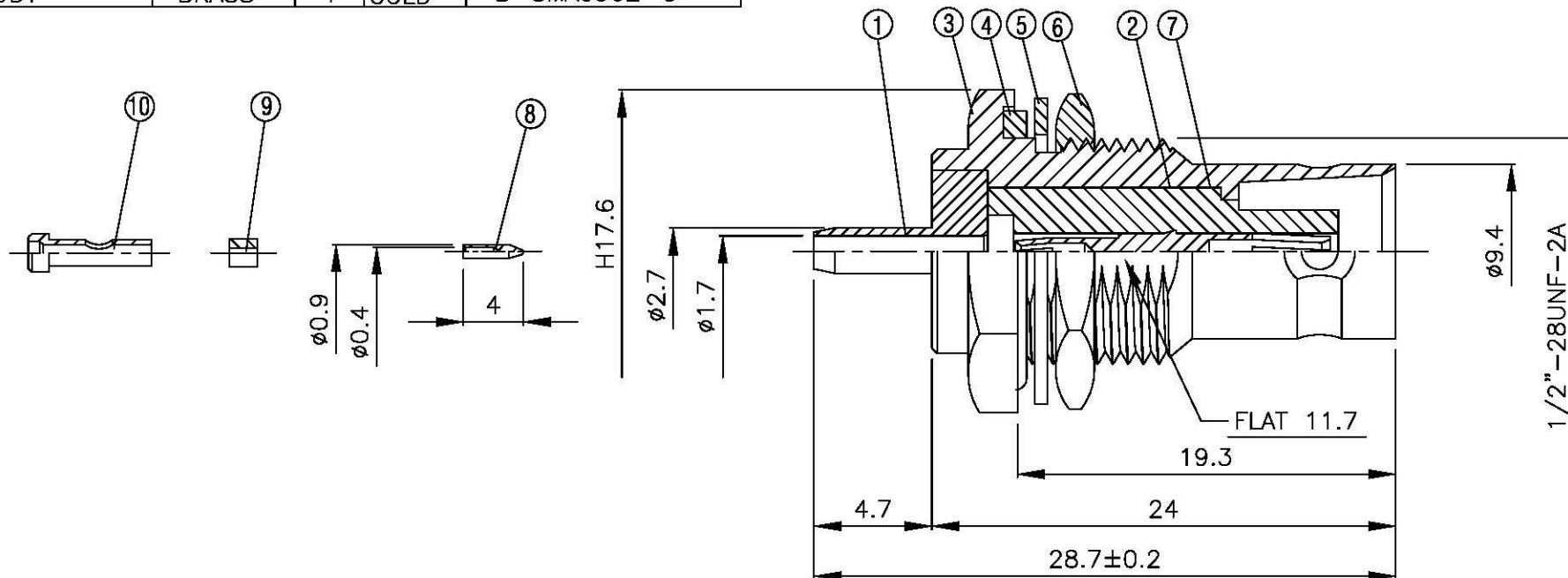
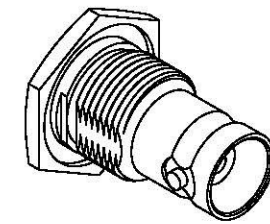
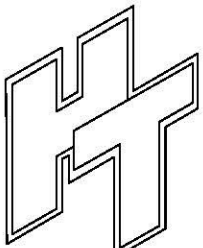

| | | | | | | |
|---|--|-----------------------------|--------------------------------------|-----------------------|-------------|----------|
|  | All Connectors <small>www.allconnectors.de Tel: 0640 711 7009503 70791 Filzelsau/L - Germany</small> | DRAWN MARY DATE 94.06.02 | DIMENSIONS ARE IN MILLIMETERS | | REVISION | |
| | | CHECKED 蘇姿潔 DATE | UNLESS OTHERWISE SPECIFIED TOLERANCE | | DESCRIPTION | ENGINEER |
| | | Q.A. 馮健華 DATE | $0.5-5 = \pm 0.2$ | $120-315 = \pm 1$ | | |
| | | APPROVAL 徐燦霖 DATE | $5-30 = \pm 0.4$ | $315-1000 = \pm 1.6$ | | |
| | | REVISION DATE | $30-120 \pm 0.6$ | $1000-2000 = \pm 2.4$ | | |
| TITLE BNC FEMALE CRIMP FOR HRS-1.1 PART NO. BNC-06U1-TGN DRAWING NO. BNC 06U1 TGN | | SCALE 4:1 | SIZE A | | | |