

| NO | DESCRIPTION | MATERIAL  | Q'TY | FINISH | REMARK      |
|----|-------------|-----------|------|--------|-------------|
| 1  | BODY        | BRASS     | 1    | NICKEL | B-TNC0929-N |
| 2  | INSULATION  | TEFLON    | 1    | TEFLON | I-0452T     |
| 3  | BODY        | BRASS     | 1    | NICKEL | B-BNC0115-N |
| 4  | GASKET      | SI RUBBER | 1    | RUBBER | RU-0006     |
| 5  | WASHER      | BRASS     | 1    | NICKEL | W-0001-N    |
| 6  | NUT         | BRASS     | 1    | NICKEL | N-0003-N    |
| 7  | PIN         | BRASS     | 1    | GOLD   | P-TNC0652-G |
| 8  | PIN         | BRASS     | 1    | GOLD   | P-FME0505-G |
| 9  | INSULATION  | TEFLON    | 1    | TEFLON | I-0256T     |
| 10 | BODY        | BRASS     | 1    | GOLD   | B-SMA0473-G |

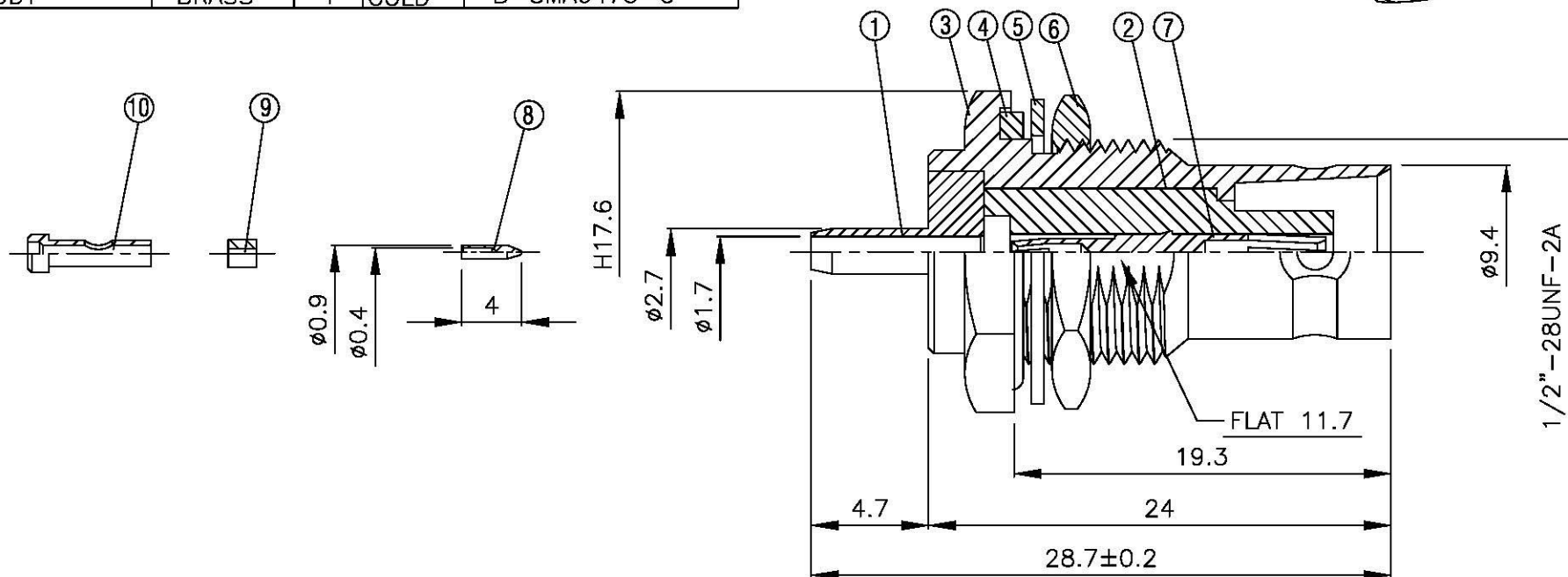
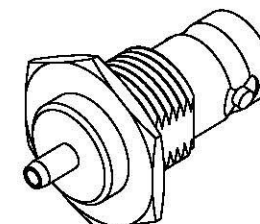

|  |   |   |                               |   |                       |             |          |
|--|---|---|-------------------------------|---|-----------------------|-------------|----------|
|  |   | DRAWN MARY<br>DATE 96.06.18   | DIMENSIONS ARE IN MILLIMETERS |   | REVISION              |             |          |
|  | <small>www.allconnectors.de<br/>Tel.: 0049 711 7009303<br/>01791 116181 - Germany</small> | <small>info@allconnectors.de<br/>Fax: 0049 711 7009304<br/>Kellernstraße 2b</small> | CHECKED 蘇志欣<br>DATE           | UNLESS OTHERWISE SPECIFIED<br>TOLERANCE |                       | DESCRIPTION | ENGINEER |
|  | TITLE BNC FEMALE CRIMP FOR<br>RG-178/U  |   | Q.A. 蘇姿潔<br>DATE              | 0.5-5 = $\pm 0.2$                       | 120-315 = $\pm 1$     |             |          |
|  | PART NO. BNC-06M-TGN  |   | APPROVAL 徐燦霖<br>DATE          | 5-30 = $\pm 0.4$                        | 315-1000 = $\pm 1.6$  |             |          |
|  | DRAWING NO. BNC 06M TGN   |   | REVISION<br>DATE              | 30-120 = $\pm 0.6$                      | 1000-2000 = $\pm 2.4$ |             |          |
|  |   |   | SCALE 4:1                     | SIZE A                                  |                       |             |          |