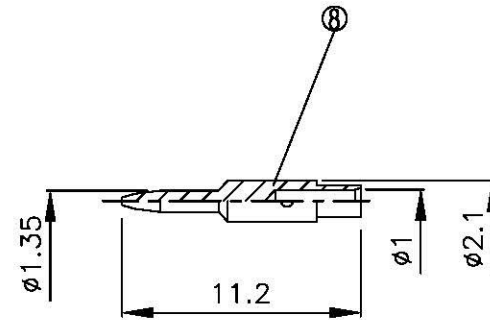
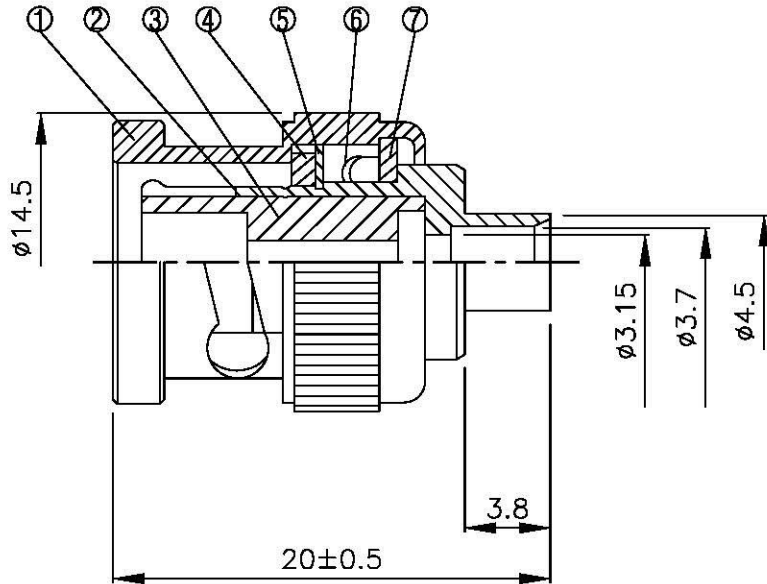
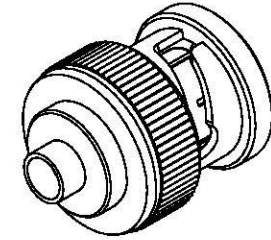
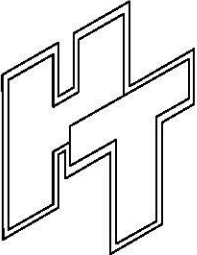

NO	DESCRIPTION	MATERIAL	Q'TY	FINISH	REMARK
1	SHELL	BRASS	1	NICKEL	B-BNC0184-N
2	BODY 1	BRASS	1	NICKEL	B-BNC0364-G
3	INSULATION	TEFLON	1	TEFLON	I-0172T
4	GASKET	RUBBER	1	RUBBER	RU-0010
5	WASHER	BRASS	1	NICKEL	W-0026-N
6	SPRING	SK-5	1	NICKEL	W-0027-N
7	WASHER	BRASS	1	NICKEL	W-0025-N
8	PIN	BRASS	1	GOLD	P-BNC0234-G

All Connectors
 www.allconnectors.de info@allconnectors.de
 TEL: 0349 711 7095008 FAX: 0349 711 7095009
 JOULE HILFENSTADT Germany KÖLN/GERMANY

TITLE BNC MALE SOLDER FOR RG 402 (.141)

PART NO. BNC-05V2-TGN

DRAWING NO. BNC 05V2 TGN

DRAWN MARY	DATE 96.06.28
CHECKED 蘇志欣	DATE
Q.A. 蘇姿潔	DATE
APPROVAL 徐燦霖	DATE
REVISION LA03/D35.A5002-75	DATE

DIMENSIONS ARE IN MILLIMETERS			
UNLESS OTHERWISE SPECIFIED TOLERANCE			
0.5-5=±0.2	120-315=±1		
5-30=±0.4	315-1000=±1.6		
30-120=±0.6	1000-2000=±2.4		
SCALE 4:1	SIZE A		

REVISION	
DESCRIPTION	ENGINEER