

NO	DESCRIPTION	MATERIAL	Q'TY	FINISH	REMARK
1	BODY 1	BRASS	1	NICKEL	B-BNC0184-N
2	INSULATION	TEFLON	1	TEFLON	I-0450T
3	GASKET	SI RUBBER	1	RUBBER	RU-0010
4	WASHER 1	BRASS	1	NICKEL	W-0026-N
5	SPRING	BRASS	1	NICKEL	W-0025-N
6	WASHER 2	BRASS	1	NICKEL	W-0027-N
7	BODY 2	BRASS	1	NICKEL	B-BNC0920-N
8	PIN (FEMALE)	BRASS	1	GOLD	P-BNC0648-G
9	PIN (MALE)	BRASS	1	GOLD	P-FME0505-G
10	INSULATION 2	TEFLON	1	TEFLON	I-0256T
11	BODY 3	BRASS	1	GOLD	B-SMA0902-G

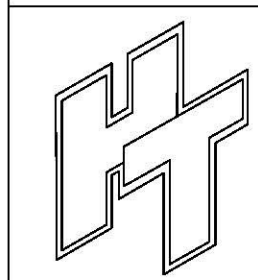
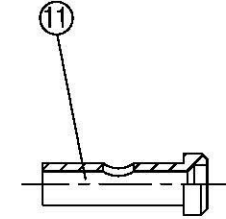
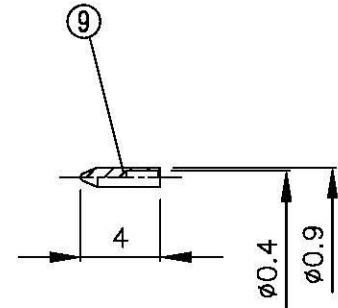
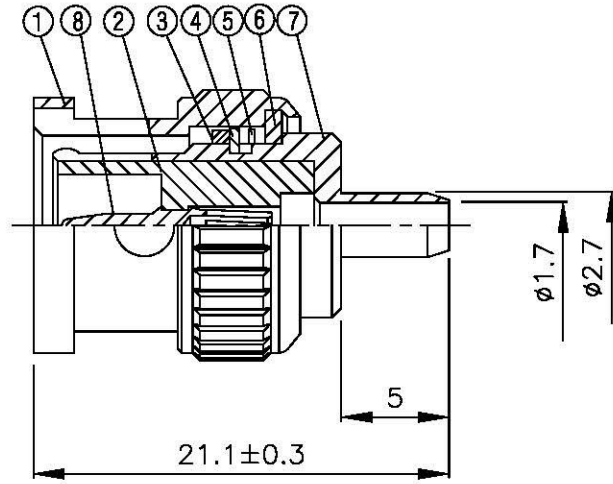
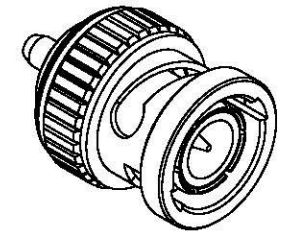

All Connectors
 www.allconnectors.de info@allconnectors.de
 Tel: 0049 711 7009503 Fax: 0049 711 7009504
 70754 Illersried - Germany Illersriederstr. 25

TITLE **BNC MALE CRIMP FOR HRS-1.1**

PART NO. **BNC-05U1-TGN**

DRAWING NO. **BNC 05U1 TGN**

DRAWN **MARY** DATE **94.05.17**

CHECKED **蘇姿潔** DATE

Q.A. **馮健華** DATE

APPROVAL **徐燦霖** DATE

REVISION DATE

DIMENSIONS ARE IN MILLIMETERS

UNLESS OTHERWISE SPECIFIED TOLERANCE

0.5-5=±0.2 120-315=±1
 5-30= ±0.4 315-1000=±1.6
 30-120±0.6 1000-2000=±2.4

SCALE **4:1** SIZE **A**

REVISION	
DESCRIPTION	ENGINEER