

NO	DESCRIPTION	MATERIAL	Q'TY	FINISH
1	BODY 1	BRASS	1	NICKEL
2	RUBBER	SI RUBBER	1	RUBBER
3	WASHER 1	BRASS	1	NICKEL
4	WASHER 2	BRASS	1	NICKEL
5	WASHER 3	BRASS	1	NICKEL
6	INSULATION	TEFLON	1	TEFLON
7	BODY 2	BRASS	1	NICKEL
8	PIN	BRASS	1	GOLD
9	RING	BRASS	NICKEL	
10	INSULATION	DELRIN	1	DELRIN

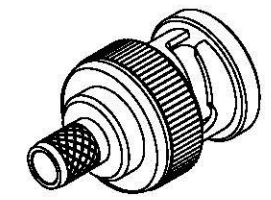

(Recommended Stripping Dimension)

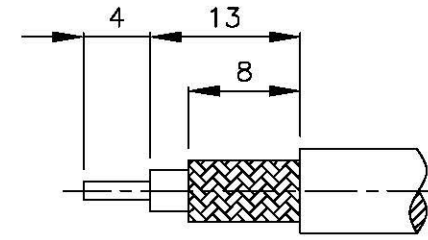
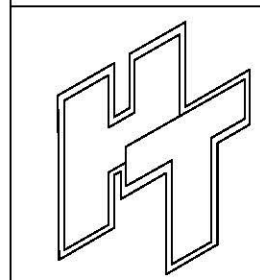
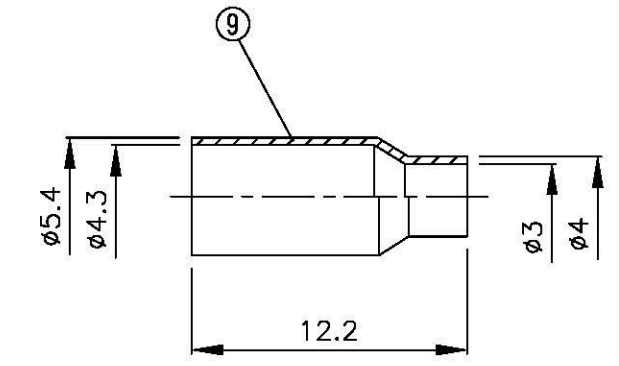
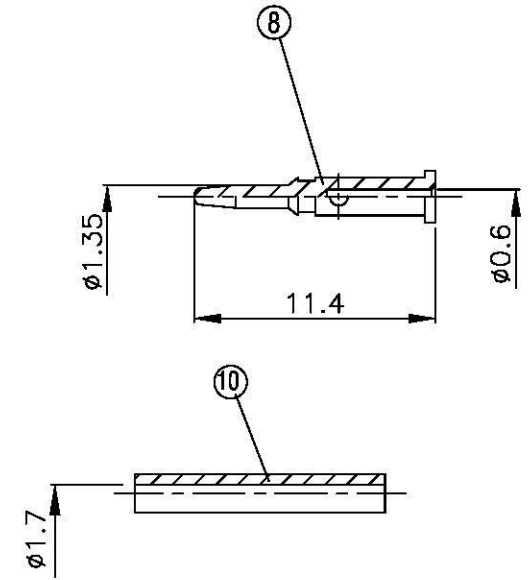
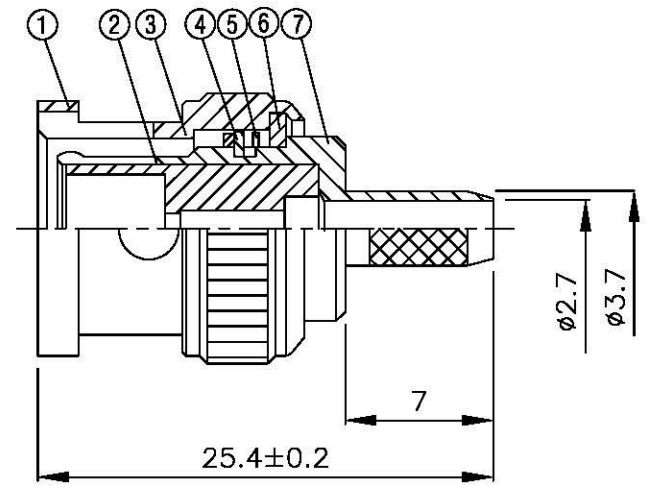

All Connectors
 www.allconnectors.de
 Tel.: 0049 711 7009503
 70791 Hildesheim - Germany
 info@allconnectors.de
 Fax: 0049 711 7009504
 Kellernstr. 25

TITLE **BNC MALE CRIMP FOR RG-174/U**

PART NO. **BNC-05L-TGN**

DRAWING NO. **BNC 05L TGN**

DRAWN **MARY** DATE **96.07.31**

CHECKED **蘇志欣** DATE

Q.A. **蘇姿潔** DATE

APPROVAL **徐燦霖** DATE

REVISION DATE

DIMENSIONS ARE IN MILLIMETERS

UNLESS OTHERWISE SPECIFIED TOLERANCE

0.5-5=±0.2	120-315=±1
5-30=±0.4	315-1000=±1.6
30-120±0.6	1000-2000=±2.4

SCALE **4:1** SIZE **A**

REVISION	
DESCRIPTION	ENGINEER