

NO	DESCRIPTION	MATERIAL	Q'TY	FINISH	REMARK
1	BODY 1	ZINE	1	NICKEL	B-BNC0184-N
2	RUBBER	SI RUBBER	1	RUBBER	RU-0010
3	WASHER 1	BRASS	1	NICKEL	W-0026-N
4	WASHER 2	BRASS	1	NICKEL	W-0027-N
5	WASHER 3	BRASS	1	NICKEL	W-0025-N
6	INSULATION	TEFLON	1	TEFLON	I-0172T
7	BODY 2	BRASS	1	NICKEL	B-TNC0085-N
8	PIN	BRASS	1	GOLD	P-TNC0222-G
9	RING	BRASS	NICKEL	R-0007-N	

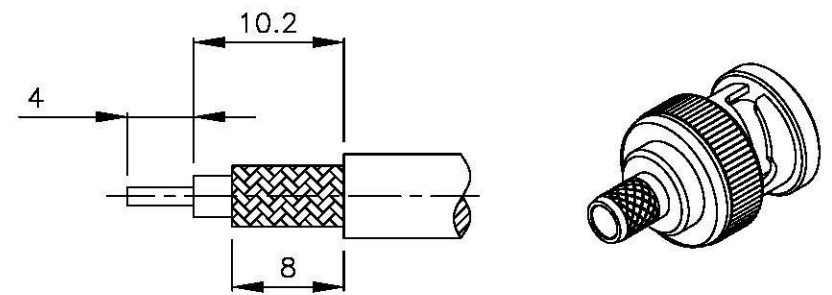

(Recommended Stripping Dimension)

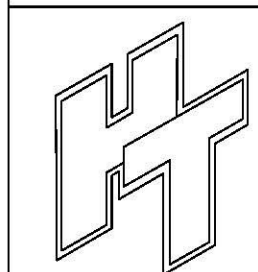
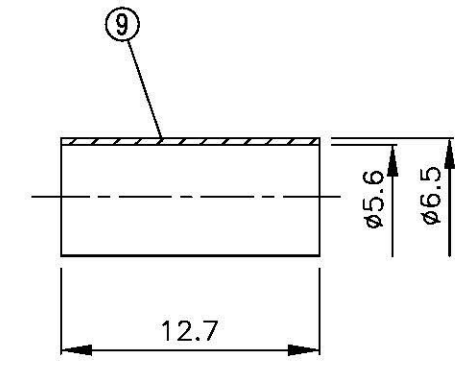
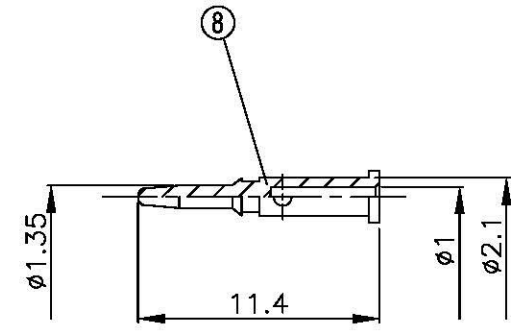
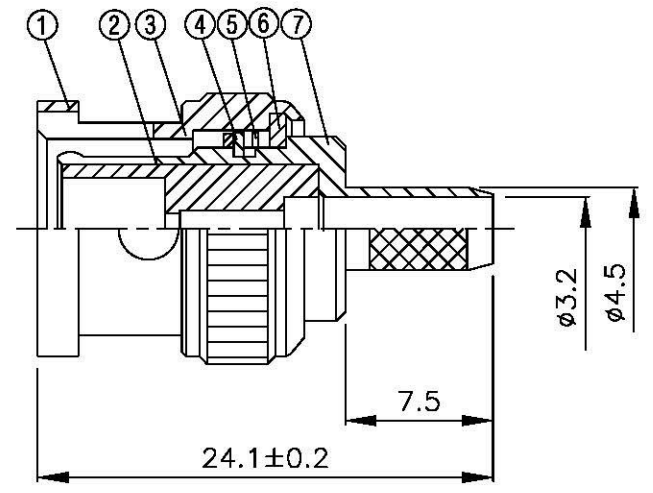

All Connectors
 www.allconnectors.de info@allconnectors.de
 Tel: 0049 713 7003500 Fax: 0049 713 7003504
 70794 Ellersdorf, Germany Kellereinstr. 25

TITLE **BNC MALE CRIMP FOR RG 58U, RG141A/U**

PART NO. **BNC-05F-TGN**

DRAWING NO. **BNC-05F-TGN**

DRAWN **MARY** DATE 90.01.22

CHECKED **蘇姿潔** DATE

Q.A. **馮健華** DATE

APPROVAL **徐燦霖** DATE

REVISION DATE

DIMENSIONS ARE IN MILLIMETERS

UNLESS OTHERWISE SPECIFIED TOLERANCE

0.5-5=±0.2	120-315=±1
5-30=±0.4	315-1000=±1.6
30-120±0.6	1000-2000=±2.4

SCALE 4:1 SIZE A

REVISION	
DESCRIPTION	ENGINEER