

NO	DESCRIPTION	MATERIAL	Q'TY	FINISH
1	BODY 1	BRASS	1	NICKEL
2	INSULATION	TEFLON	1	TEFLON
3	PIN	BRASS	1	GOLD
4	SLEEVE	BRASS	1	NICKEL
5	GASKET	SI RUBBER	1	RUBBER
6	WASHER	BRASS	1	NICKEL
7	NUT	BRASS	1	NICKEL
8	WASHER	BRASS	1	NICKEL

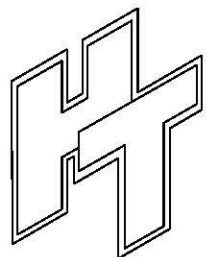
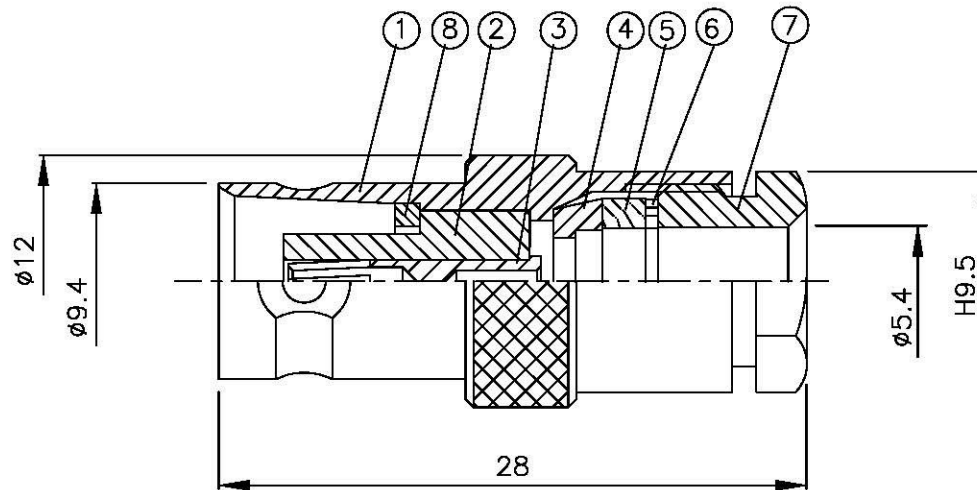
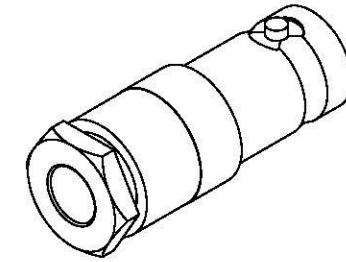

All Connectors

www.allconnectors.de
Tel: +0049 211 208503
20798 Hildersdorf, Germany

in: Europe
www.allconnectors.de
Fax: +0049 211 208504
Kaltensuhl, 20

TITLE **BNC FEMALE CLAMP
FOR RG-58/U**

PART NO. **BNC-03F-TGN**

DRAWING NO. **BNC 03F TGN**

DRAWN **MARY** DATE **95.12.21**

CHECKED **黃巧君** DATE

Q.A. **蘇姿潔** DATE

APPROVAL **徐燦霖** DATE

REVISION DATE

DIMENSIONS ARE IN MILLIMETERS

UNLESS OTHERWISE SPECIFIED
TOLERANCE

0.5-5=±0.2 120-315=±1

5-30=±0.4 315-1000=±1.6

30-120=±0.6 1000-2000=±2.4

SCALE **4:1** SIZE **A**

REVISION

DESCRIPTION ENGINEER