

NO	DESCRIPTION	MATERIAL	Q'TY	FINISH
1	SHELL	BRASS	1	NICKEL
2	BODY 1	BRASS	1	NICKEL
3	GASKET	SI RUBBER	1	RUBBER
4	WASHER	BRASS	1	NICKEL
5	SPRING	SK-5	1	NICKEL
6	WASHER	BRASS	1	NICKEL
7	INSULATION	DELTRIN	1	DELTRIN
8	PIN	BRASS	1	GOLD
9	BODY 2	BRASS	1	NICKEL
10	WASHER	BRASS	1	NICKEL
11	INSULATION	TEFLON	1	TEFLON
12	RING	BRASS	1	NICKEL

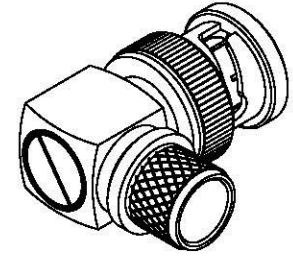

D

D

C

C

B

B

A

A

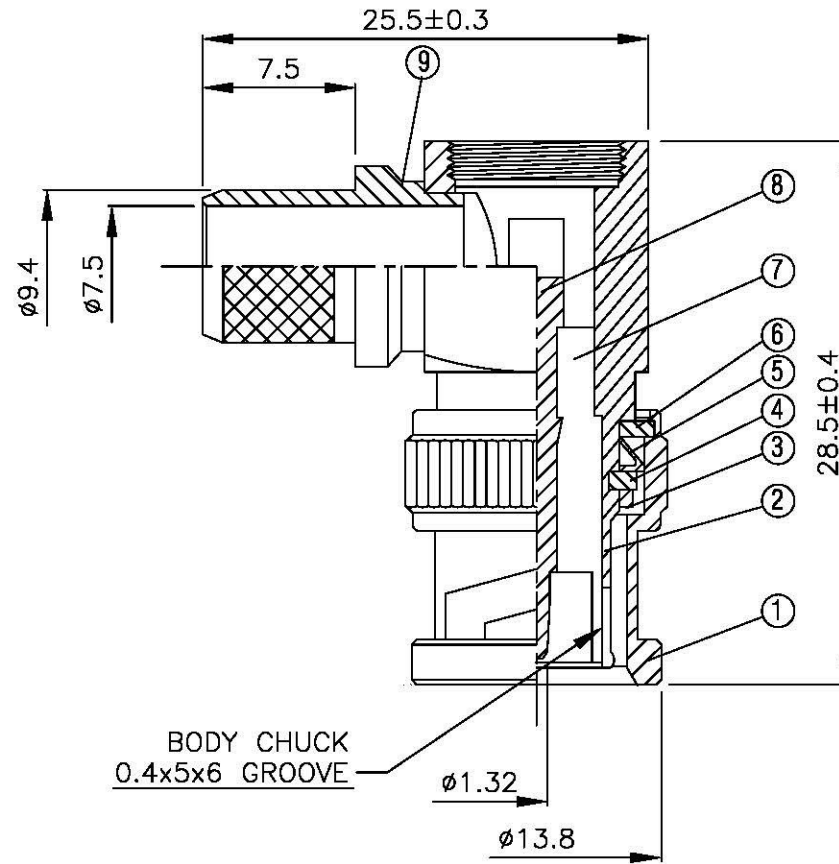
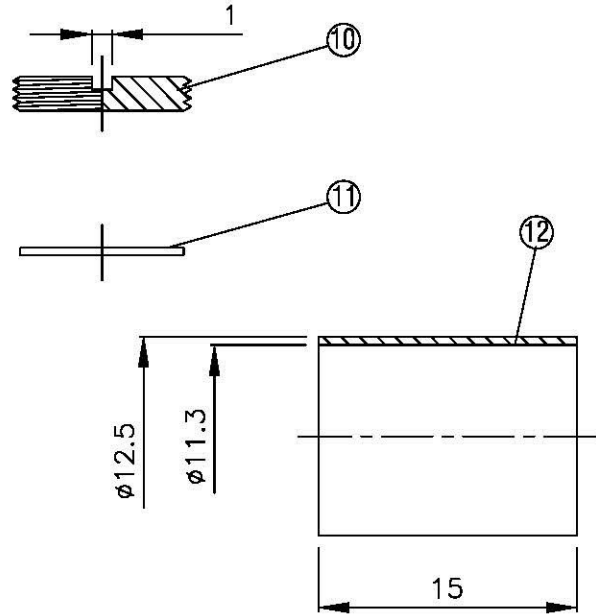

Allconnectors

www.allconnectors.de info@allconnectors.de
Tel: 0049 711 7006503 Fax: 0049 711 7006504
72754 Tüdingen - Germany

TITLE **BNC MALE ANGLE CRIMP FOR RG-213/U**

PART NO. **BNC-02B-DGN**

DRAWING NO. **BNC 02B DGN**

DRAWN **MARY**

DATE **96.06.18**

CHECKED **蘇志欣**

DATE

Q.A. **蘇姿潔**

DATE

APPROVAL **徐燦霖**

DATE

REVISION

DATE

DIMENSIONS ARE IN MILLIMETERS

UNLESS OTHERWISE SPECIFIED TOLERANCE

0.5-5=±0.2 120-315=±1

5-30=±0.4 315-1000=±1.6

30-120=±0.6 1000-2000=±2.4

SCALE **4:1** SIZE **A**

REVISION

DESCRIPTION ENGINEER

4

3

2

1