

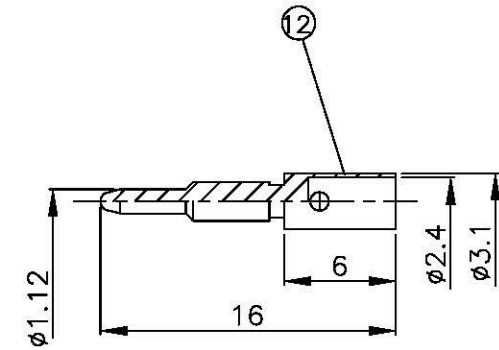

NO	DESCRIPTION	MATERIAL	Q'TY	FINISH
1	BODY 1	BRASS	1	NICKEL
2	RUBBER	SI RUBBER	1	RUBBER
3	WASHER 1	BRASS	1	NICKEL
4	WASHER 2	BRASS	1	NICKEL
5	WASHER 3	BRASS	1	NICKEL
6	INSULATION	TEFLON	1	TEFLON
7	BODY 2	BRASS	1	NICKEL
8	BODY 3	BRASS	1	NICKEL
9	RUBBER	SI RUBBER	1	RUBBER
10	WASHER	BRASS	1	NICKEL
11	NUT	BRASS	1	NICKEL
12	PIN	BRASS	1	GOLD

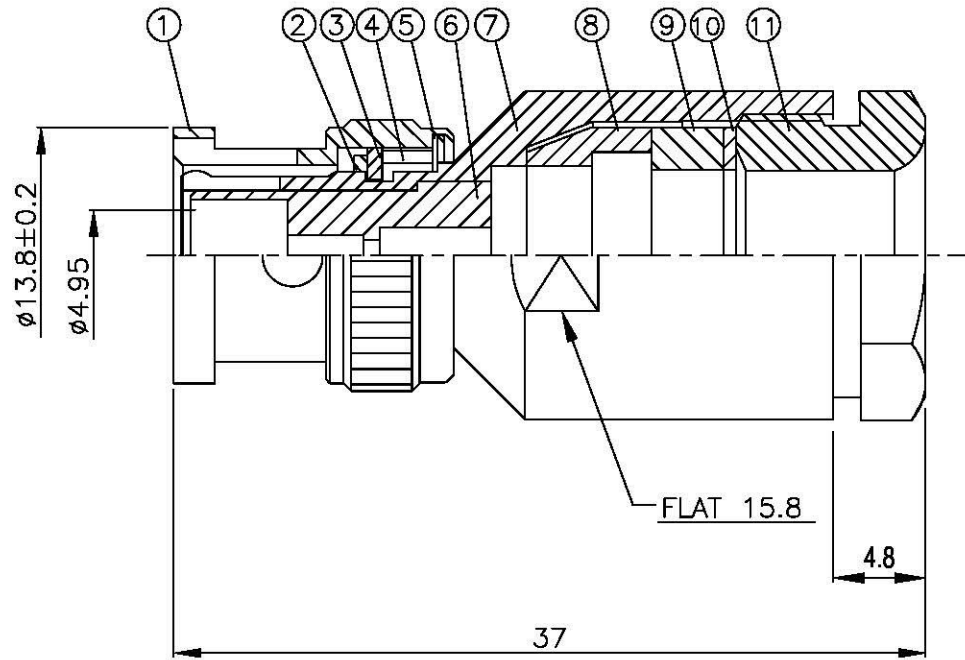
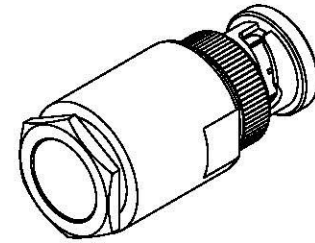
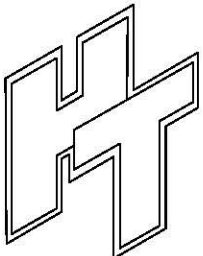

		DRAWN MARY DATE 95.11.27	DIMENSIONS ARE IN MILLMETERS		REVISION		
	<small>www.allconnectors.de Tel.: 0049 711 709204 70794 Filberfeld - Germany</small>	<small>info@allconnectors.de Fax: 0049 711 709204 Kellernstr. 25</small>	CHECKED 黄巧君 DATE	UNLESS OTHERWISE SPECIFIED TOLERANCES		DESCRIPTION	ENGINEER
	TITLE BNC MALE CLAMP FOR RG-213/U	Q.A. 蘇姿潔 DATE	APPROVAL 徐燦霖 DATE	0.5-5 = ± 0.2	120-315 = ± 1		
	PART NO. BNC-01B-TGN	REVISION	DATE	5-30 = ± 0.4	315-1000 = ± 1.6		
	DRAWING NO. BNC 01B TGN		DATE	30-120 = ± 0.6	1000-2000 = ± 2.4		
			SCALE 4:1	SIZE A			