

NO	DESCRIPTION	MATERIAL	Q'TY	FINISH	REMARK
1	BODY 1	BRASS	1	SILVER	B-7160338-S
2	GASKET	SI RUBBER	1	RUBBER	RU-0020
3	BODY 2	BRASS	1	SILVER	B-7160339-S
4	INSULATION 1	TEFLON	1	TEFLON	I-0163T
5	PIN	BRASS	1	SILVER	P-7160213-S
6	BODY 3	BRASS	1	SILVER	B-7160340-S
7	INSULATION 2	TEFLON	1	TEFLON	I-0165T
8	WASHER	PH.BRONZE	1	NICKEL	W-0014
9	BODY 4	BRASS	1	SILVER	B-N0033-S
10	GASKRT	SI RUBBER	1	RUBBER	RU-0007
11	BODY 5	BRASS	1	SILVER	B-N003

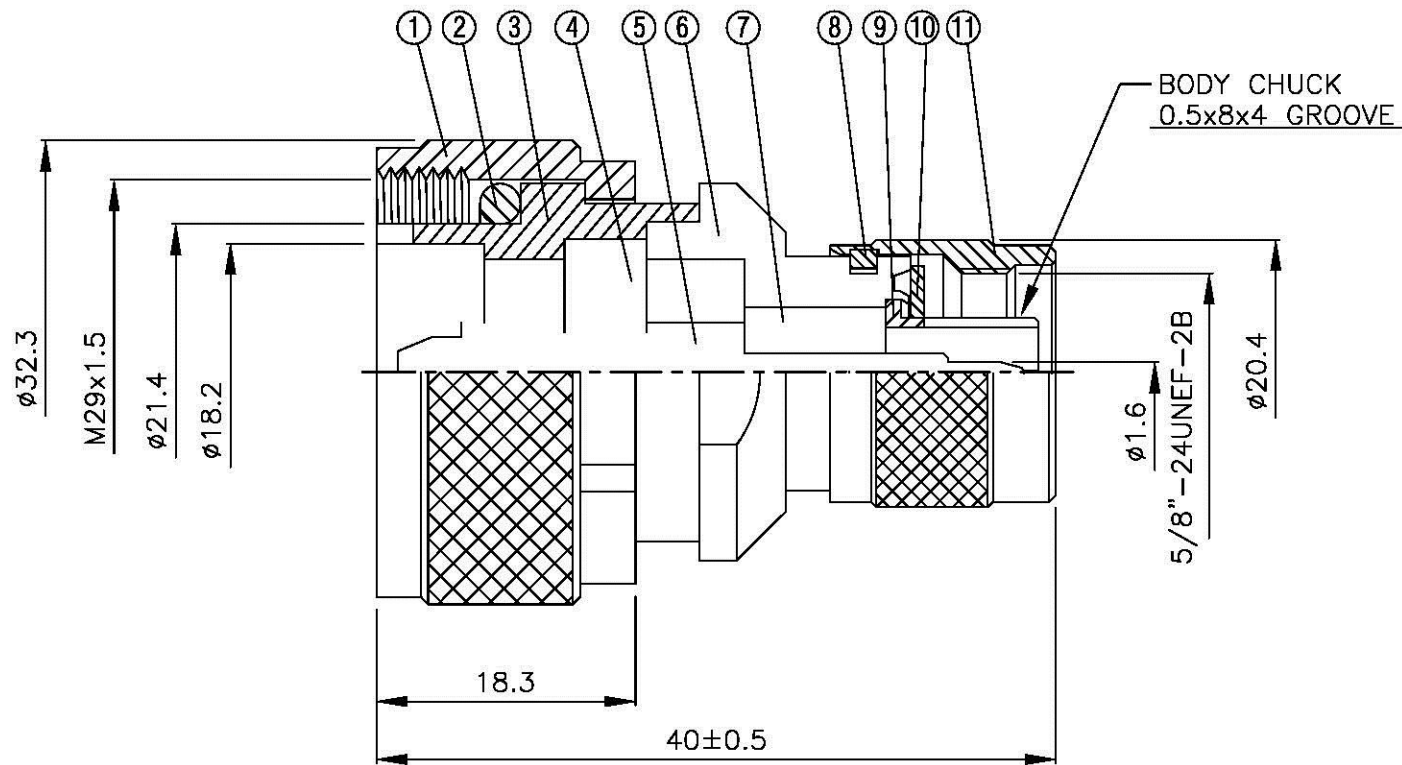
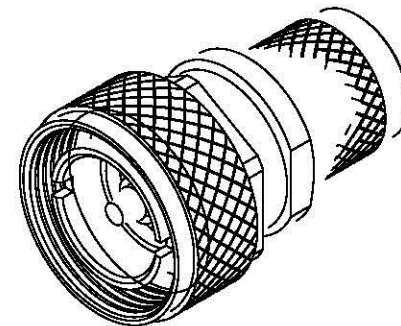

		DRAWN MARY CHECKED Q.A. APPROVAL REVISION	DATE 96.08.30 DATE DATE DATE	DIMENSIONS ARE IN MILLIMETERS UNLESS OTHERWISE SPECIFIED TOLERANCE 0.5-5=±0.2 120-315=±1 5-30=±0.4 315-1000=±1.6 30-120±0.6 1000-2000=±2.4	REVISION		
	www.allconnectors.de Tel.: 0049 711 7008008 200281 Hildesheim - Germany	info@allconnectors.de Fax: 0049 711 7009004 info@connectors.de			SCALE 4:1 SIZE A	DESCRIPTION	ENGINEER
	TITLE 7/16 MALE -N MALE						
	PART NO. 716-11-TSS						
	DRAWING NO. 716 11 TSS						