

NO	DESCRIPTION	MATERIAL	Q'TY	FINISH	REMARK
1	BODY 1	BRASS	1	SILVER	B-7160343-S
2	PIN 1	BE CU	1	SILVER	P-7160421-S
3	INSULATION 1	TEFLON	1	TEFLON	I-0211T
4	PIN 2	BRASS	1	SILVER	P-7160214-S
5	INSULATION 2	TEFLON	1	TEFLON	I-0121T
6	BODY 2	BRASS	1	SILVER	B-7160344-S
7	WASHER	PH.BRONZE	1	SILVER	W-0014
8	GASKET	SI RUBBER	1	RUBBER	RU-0007
9	BODY 3	BRASS	1	SILVER	B-N0032-S
10	BODY 4	BRASS	1	SILVER	B-N0033-S
10	GASKET	SI RUBBER	1	RUBBER	RU-0023

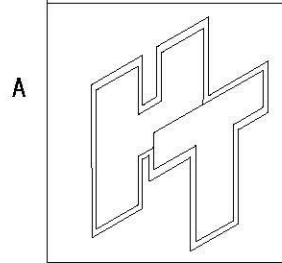
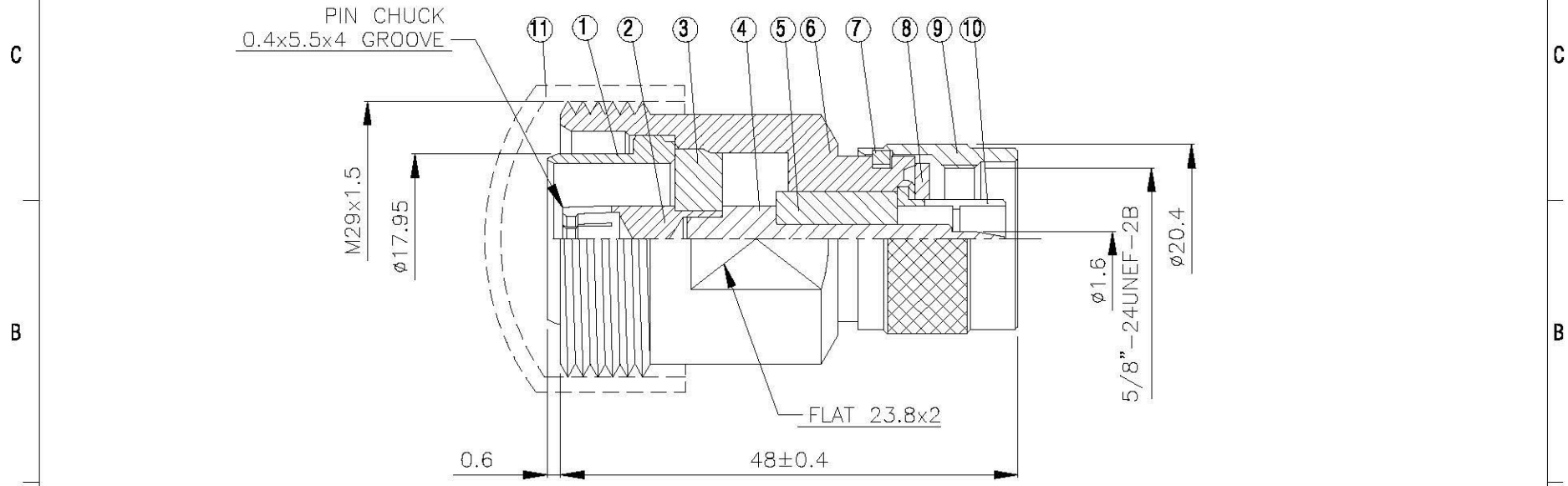
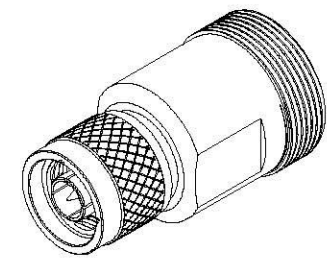

**All Connectors**  
 www.allconnectors.de  
 info@allconnectors.de  
 70794 Hilderstraße, Germany

**TITLE** 7/16 FEMALE -N MALE  
**PART NO.** 716-10-TSS  
**DRAWING NO.** 716 10 TSS

**DRAWN** MARY **DATE** 96.08.30  
**CHECKED** 蘇志欣 **DATE**  
**Q.A.** 蘇姿潔 **DATE**  
**APPROVAL** 徐燦霖 **DATE**  
**REVISION** **DATE**

**DIMENSIONS ARE IN MILLIMETERS**  
**UNLESS OTHERWISE SPECIFIED TOLERANCE**  
 0.5-5=±0.2 120-315=±1  
 5-30= ±0.4 315-1000=±1.6  
 30-120±0.6 1000-2000=±2.4  
**SCALE** 4:1 **SIZE** A

REVISION	
DESCRIPTION	ENGINEER